

# Robitussin<sup>®</sup>

## OWNER'S MANUAL

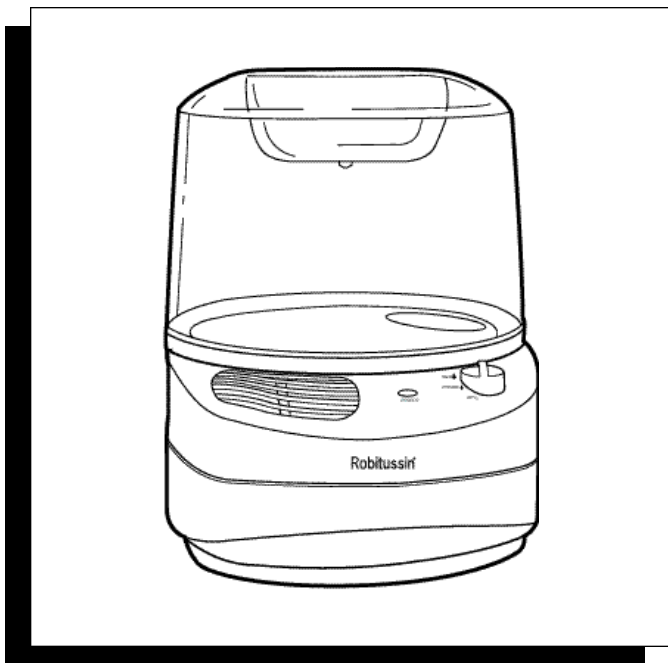

**1.0 GALLON OUTPUT PER DAY\*  
NATURAL COOL MOISTURE™ HUMIDIFIER**

Model DH-832 Series

\*Output dependent on room temperature and humidity.  
Robitussin<sup>®</sup> is a registered trademark of Whitehall-Robins Healthcare.

# **IMPORTANT SAFETY INSTRUCTIONS**

---

## **READ AND SAVE THESE SAFETY INSTRUCTIONS BEFORE USING THIS HUMIDIFIER**

**When using electrical appliances, basic precautions should always be followed to reduce the risk of fire, electric shock, and injury to persons, including the following:**

- 1.** Always place this humidifier on a firm, flat and level surface. This humidifier may not work properly on an uneven surface.
- 2.** Place this humidifier in an area where it is not accessible to children.
- 3.** Do not place the humidifier near any heat sources such as stoves, radiators, and heaters.
- 4.** Before using the humidifier, check the power cord for any signs of damage. If the cord is found to be damaged, **DO NOT USE** and return the humidifier to the manufacturer under the warranty agreement for repair.
- 5.** This appliance has a polarized plug (one blade is wider than the other). To reduce the risk of shock, this plug is intended to fit only one way in a polarized outlet. If the plug does not fit fully in the outlet, reverse the plug. If it still does not fit, contact a qualified electrician. **DO NOT attempt to defeat this safety feature.**
- 6.** To disconnect the humidifier, first turn controls to the OFF position, then grip the plug and pull it from the wall outlet. Never pull by the cord.
- 7.** A loose fit between the AC outlet (receptacle) and plug may cause overheating and a distortion of the plug. Contact a qualified electrician to replace loose or worn outlet.
- 8.** The humidifier should always be unplugged and emptied when not in operation or while being serviced or cleaned.
- 9.** Never tilt or attempt to move the humidifier while it is operating or filled with water. **UNPLUG** the humidifier before moving.
- 10.** This humidifier requires regular cleaning. Refer to the CLEANING instructions provided. Never clean the humidifier in any manner other than as instructed in this manual.
- 11.** Turn the humidifier OFF if the relative humidity exceeds 60%, or if you notice moisture on the inside of your windows. For proper humidity reading use a hygrometer, which is available in many hardware and department stores, or by ordering one from manufacturer. (See CARE PRODUCTS.)

Thank you for purchasing a Robitussin® Natural Cool Moisture™ Humidifier.

### HOW DOES IT WORK?

#### NATURAL COOL MOISTURE™ SYSTEM

Dry air is pulled through the Natural Cool Moisture™ system and a quiet fan blows out invisible, moisture-balanced air. Unwanted minerals and bacteria from the water are trapped inside the Natural Cool Moisture™ filter. When the unit is running you will not see or feel a “mist”. You will know your humidifier is putting moisture into the air as you watch the water level in your tank decrease throughout the day.

#### WHAT IS HEALTHSHIELD™ ANTIMICROBIAL?

Your Robitussin® Natural Cool Moisture™ filter has been designed using new HealthShield™\* technology which prevents surface growth and migration of mold, fungus and bacteria in the filter for its life - approximately one season. Keep in mind, depending on your water quality, mineral deposits can still clog or discolor the filter, affect its life and that of the humidifier.

#### MODEL - DH-832:

Your humidifier is made up of these parts:

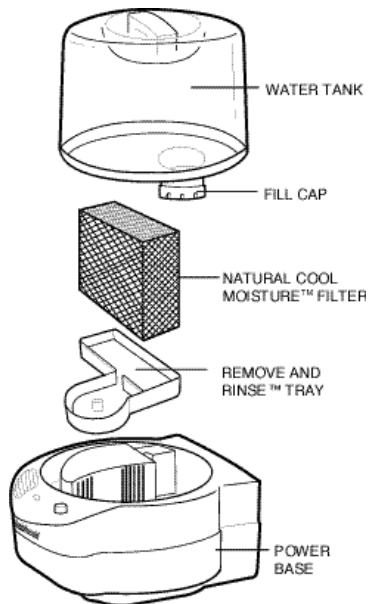



\*HealthShield is registered with the Environmental Protection Agency (EPA).

**NOTE: We recommend that the humidifier be disinfected prior to first use. Please see CLEANING instructions.**

- Select a firm, level, flat location - at least six inches (15 cm) from any wall for proper air flow (Fig. 1). Place the humidifier on a water-resistant surface, as water can damage furniture and some flooring.

*The manufacturer will not accept responsibility for property damage caused by water spillage.*

## FILLING

- Remove the water tank by grasping handle and pulling straight up. Set aside (Fig. 1).
- Remove the Natural Cool Moisture™ filter from the base before filling the unit with water (Fig. 2). Soak filter in a sink full of cool water to help reduce mineral build up and place back in the humidifier while wet. **DO NOT SQUEEZE OR WRING OUT THE NATURAL COOLMOISTURE™ FILTER.** To help extend the life of your filter repeat this step each time you fill your humidifier.
- Turn the Water Tank upside down so that the Fill Cap is facing up; unscrew the Fill Cap by turning it counter-clockwise  and set aside.
- Fill the Water Tank with COOL tap water (Fig. 3). Distilled water is not necessary as the water is filtered by the Natural Cool Moisture™ filter. **DO NOT USE HOT WATER.** Doing so may damage the humidifier.
- Replace the fill cap by turning it clockwise . **DO NOT OVER TIGHTEN.** Turn the Water Tank right-side up.

**NOTE: WHEN CARRYING THE FILLED WATER TANK PLEASE USE THE HANDLE AND PLACE YOUR OTHER HAND UNDER THE TANK FOR ADDITIONAL SUPPORT.**

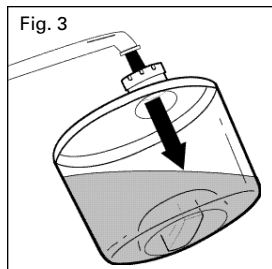
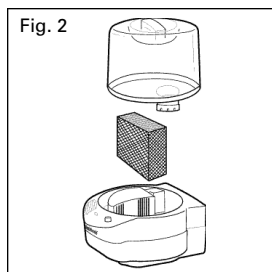
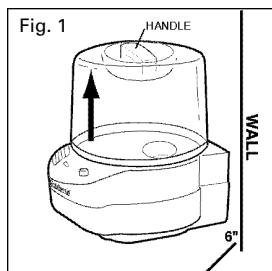

- Position the Water Tank in the humidifier and push into place. Some water will empty into the base.
- Once the filled tank has been positioned, do not attempt to move the humidifier. If it has to be moved, unplug the humidifier and remove the water tank first.

**CAUTION: DO NOT POUR WATER INTO THE GRILLE ON THE POWER BASE.  
DOING SO MAY DAMAGE THE HUMIDIFIER OR CAUSE PERSONAL INJURY.**

---

## OPERATION

### POWER

**CAUTION: DO NOT PLUG IN THE HUMIDIFIER WITH WET HANDS AS AN ELECTRICAL SHOCK COULD OCCUR.**

- With the power switch in the OFF position, plug the filled humidifier into a polarized 120V outlet. **DONOT FORCETHE POLARIZEDPLUG INTO THEOUTLET;** it will only fit one way.

### HUMIDITY CONTROL

- Set the fan speed CONTROL to the desired position (Fig. 4).  
HIGH: For fast humidifying  
NORMAL: For quieter operation

**NOTE:** The length of time your humidifier runs will vary depending on the quality of construction, room size, and insulation of your room and house, as well as the fan speed.

- Turn the humidifier OFFif the humidity level feels too moist or you notice condensation forming on the walls and/or windows.
- **ALWAYS**besure to empty any unused water ni the Remove and Rinse™ Tray and/or Water Tank each time you refill the water tank or finish using the humidifier.

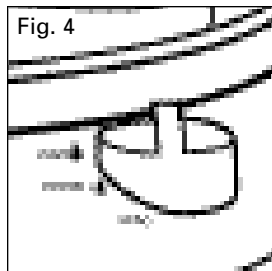

We recommend cleaning the humidifier once a week, more often if you have hard water, notice a build up of impurities or detect unpleasant odors.

**Cleaning involves two steps SCALE REMOVAL and DISINFECTING. Be sure to perform these in the proper order to avoid harmful chemical interactions.**

- First, turn off and unplug the humidifier.
- Remove the Water Tank.
- **Remove the Natural Cool Moisture™ filter from the Base.**
- Empty any water from the Base.

**NOTE: REMOVE FILTER BEFORE CLEANING.  
Failure to remove filter during cleaning will destroy the filter.**

### STEP ONE: SCALE REMOVAL

#### REMOVE AND RINSE TRAY™

1. Fill the Remove and Rinse Tray™ with either:

- 1 cup (8 ozs.) of undiluted white vinegar

**or**

- Use DuraRinse™ Humidifier Cleaner, part no. AC816, following the instructions on the bottle.

2. Let solution stand for 20 minutes.

3. With the vinegar or DuraRinse™ in the Remove and Rinse Tray™ clean all interior surfaces with a soft cloth or brush to help remove scale.

4. Rinse thoroughly with water to remove scale and cleaning solution.

### STEP TWO: DISINFECTING

#### WATER TANK/REMOVE AND RINSE TRAY™

1. Fill the Water Tank with:

- 1 teaspoon of household bleach

**and**

- 1 gallon of water
- Pour some of this solution into the Remove and Rinse Tray™.

2. Let solution stand for 20 minutes.

3. Rinse with water until the odor of bleach is gone.

**NOTE: THE USE OF OTHER WATER TREATMENT PRODUCTS AND CHEMICALS MAY CAUSE DETERIORATION OF THE FILTER OR DAMAGE THE HUMIDIFIER, THEREBY HINDERING THE HUMIDIFIER'S EFFECTIVENESS.**

## **PROLONGING THE LIFE OF THE FILTER AND MAINTAINING A CLEAN HUMIDIFIER**

---

**NOTE:** DONOT ATTEMPT TO CLEAN THE NATURAL COOL MOISTURE™ FILTER WITH ANY CHEMICAL SOLUTIONS, DOING SO WILL DAMAGE THE FILTER.

- HealthShield™ prevents the surface growth and migration of mold, fungus, algae, and bacteria. It is normal for a filter to discolor from mineral build-up. This will vary depending on water quality.
- DONOT clean the filter using any chemical solution.
- If a Natural Cool Moisture™ filter appears to be clogged by hard water or mineral deposits, soak it in a sink full of cool water for 10 minutes. DO NOT SQUEEZE OR WRING OUT THE NATURAL COOLMOISTURE™ FILTER. Always place filter back in the humidifier wet.
- When positioning the Natural Cool Moisture™ filter in the humidifier, always make sure the diamond pattern is displayed lengthwise (see diagram below).

### Close-Up of Filter Pad

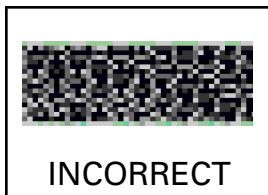
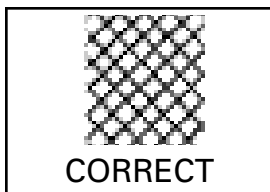

- To prevent mineral deposits use DuraFree™ Humidifier Water Softener, part no. AC817, each time the Water Tank is refilled.
- Always purchase Honeywell brand Natural Cool Moisture™ filters as the fan motor of this humidifier and the Natural Cool Moisture™ filter are designed to function efficiently as a set. Using any other filter could damage the motor or reduce the humidifier's performance.
- Be sure to empty water from the Water Tank and Base when not in use.

## **END-OF-THE-SEASON CARE AND STORAGE**

---

- Follow weekly **CLEANING** instructions when the humidifier will not be used for at least one week or more, or at the end of the season.
- At the end of the season, remove and throw away the filter; do not store with a used filter.
- Dry the humidifier completely before storing. **DO NOT** store with water inside the Base, Water Tank, or Remove and Rinse Tray™.
- Pack the unit in its original carton and store in a cool, dry location.
- Before next use, remember to install a new filter and clean the humidifier.

## **TROUBLE SHOOTING**

---

**Q: I hear the fan turning, but I don't see any mist. Is my humidifier operating properly?**

**A:** Dry air is pulled through the Natural Cool Moisture™ system and a fan disperses invisible, moisture balanced air. There is no "mist" emitted. When operating normally you will feel only cool air coming from the unit. Monitor the water level in your Tank/ Base. If you notice a decrease in the Water Tank over 24 hours then the unit is operating normally.

**Q: My unit has been running for several hours. I hear the fan spinning, but I do not notice the water level in the tank decreasing.**

**A:** First, check the Natural Cool Moisture™ filter to be sure it is wet. If the pad appears dry, remove it from the Base and gently rinse under cool water. Reposition wet filter in the Base. You may also want to note the current moisture level in your home. If the humidity level is over 60% the unit will not put out much moisture as your air is already saturated.

**Q: My filter has turned light brown and rust colored. Do I need a new filter?**

**A:** Probably not. Since your filter has been made with HealthShield™ technology the change in color indicates only a mineral deposit. Soak filter in a sink full of cool water to help break up deposits. The discoloration may remain but will not affect the humidifier's performance.

## **ELECTRICAL RATINGS**

---

This product is rated 0.4 Amps at 120V, 60 Hz.

**NOTE: IF YOU EXPERIENCE A PROBLEM WITH YOUR HUMIDIFIER'S POWER UNIT, PLEASE SEE THE WARRANTY FOR INSTRUCTIONS. PLEASE DO NOT ATTEMPT TO OPEN OR REPAIR THE HUMIDIFIER YOURSELF. DOING SO WILL VOID THE WARRANTY AND COULD CAUSE DAMAGE OR PERSONAL INJURY. IF THE PROBLEM PERSISTS, PLEASE CONTACT THE CONSUMER SERVICE CENTER.**

## **CUSTOMER ASSISTANCE**

---

Mail questions or comments to:

Honeywell  
Consumer Service Center  
250 Turnpike Road  
Southborough, MA 01772  
e-mail: [service@honeywell.com](mailto:service@honeywell.com)

**Please be sure to specify model number.**

Call us toll-free at: 1-800-332-1110



or visit our website at:  
[www.honeywell.com/yourhome](http://www.honeywell.com/yourhome)

**CARE PRODUCTS**

If your local dealer is out of stock, replacement parts and care products may be ordered directly from the manufacturer. You can call 1-800-332-1110 to order with a MasterCard, Visa or Discover or fill out the form below and mail it along with a check or money order (sorry no COD's accepted) to:

Honeywell  
 Consumer Service Center  
 250 Turnpike Road  
 Southborough, MA 01772

Please allow four to six weeks for delivery.  
 Massachusetts residents please add 5% Sales Tax.

Item	Item No.	Qty.	US Price	Total
Natural Cool Moisture™ Filter, one per pack	AGW813		\$ 9.99	
DuraFree® Humidifier Water Softener (32 oz.)	AC817		5.00	
DuraRinse® Humidifier Cleaner (32 oz.)	AC816		5.00	
Rinse-to-Clean Base	DH830-1		10.00	
Water Tank and Fill Cap	DH830-2		19.99	
Fill Cap	DH830-3		5.00	
 Digital Hygrometer and Thermometer(F°/C°) <small>Measure room temperature and humidity level.        Free standing can be used anywhere in the room.</small>	HAC555		19.99	
<b>SUBTOTAL</b>				
<b>MAResidents add 5% Sales Tax</b>				
<b>Shipping and Handling (US residents add \$4.95)</b>				
<b>TOTAL ENCLOSED</b>				
Name	Check or Money Order Enclosed			<input type="checkbox"/>
Address	Credit Card No.			<input type="checkbox"/>
	Exp. Date			
Day Time Phone	Signature			

### THREE YEAR LIMITED WARRANTY TERMS AND CONDITIONS

You should first read all instructions before attempting to use this product. **The enclosed Customer response card should be filled out and returned within 7 days of purchase.**

- A. This 3 year Limited Warranty applies to repair or replacement of product found to be defective in material or workmanship during the warranty period. This warranty does not apply to damage resulting from commercial, abusive, unreasonable use, or supplemental damage. Defects that are the result of normal wear and tear will not be considered manufacturing defects under this warranty. You should first read all instructions before attempting to use this product. **THE MANUFACTURER IS NOT LIABLE FOR INCIDENTAL OR CONSEQUENTIAL DAMAGES OF ANY NATURE. ANY IMPLIED WARRANTY OF MERCHANTABILITY OR FITNESS FOR A PARTICULAR PURPOSE ON THIS PRODUCT IS LIMITED IN DURATION TO THE DURATION OF THIS WARRANTY.** Some jurisdictions do not allow the exclusion or limitation of incidental or consequential damages, or limitations on how long an implied warranty lasts, so the above limitations or exclusions may not apply to you. This warranty gives you specific legal rights, and you also may have other rights which vary from jurisdiction to jurisdiction. This warranty applies only to the original purchaser of this product from the original date of purchase.
- B. At its option, the manufacturer will repair or replace this product if it is found defective in material or workmanship within the warranty period. Defective product should be returned to the place of purchase in accordance with store policy. Thereafter, while within the warranty period, any defective product should be returned to the manufacturer.

**NOTE: THIS WARRANTY DOES NOT COVER THE NATURAL COOL MOISTURE™ FILTER, WHOSE PERFORMANCE WILL DEPEND UPON THE CONDITION OF THE WATER USED IN THE HUMIDIFIER.**

- C. This warranty does not cover damage resulting from any unauthorized attempts to repair or from any use not in accordance with the instruction manual.
- D. Return defective product, freight paid, with proof of purchase and \$10 U.S. check or money order for handling, return packing and shipping charges, to:

Honeywell

ATTN: Returns Department  
4755 Southpoint Drive  
Memphis, TN 38118, U.S.A  
1-800-332-1110