

READ AND SAVE THESE INSTRUCTIONS

DRI-STEEM

MODEL STS[®] and STS-DI[®]

STEAM-TO-STEAM HUMIDIFIERS

**Installation Instructions
and
Maintenance Operations
Manual**

**For Toll-Free Technical Support,
Call 1-800-328-4447**



UL LISTED



CUL LISTED

DRI STEEM[®]
HUMIDIFIER COMPANY

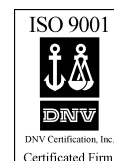

TABLE OF CONTENTS

TO THE PURCHASER AND THE INSTALLER

Thank you for purchasing DRI-STEEM STS® humidification equipment. We have designed and built this equipment to give you total satisfaction and many years of trouble-free service. Proper installation and operating practices will assure you of achieving that objective. We urge you to become familiar with the contents of this manual.

DRI-STEEM Humidifier Company

STS and STS-DI Humidifiers	3
Capacities and Dimensions	4
Mounting Methods	6
Piping	8
Piping Diagrams: Steam, Water and Drain	11
Electrical	12
Steam Dispersion Installation	13
RAPID-SORB® Assembly and Installation	
• Horizontal Duct Installation	15
• Vertical Duct Installation	16
Start-Up and Operation	
• Water Control with VAPOR-LOGIC ₂	17
Recommended Maintenance	18
STS-DI Start-up and Recommended Maintenance	19
Trouble Shooting Guide	20
Replacement Parts	21
Two-Year Limited Warranty	24

STS® AND STS®-DI HUMIDIFIERS

STS Humidifier (For use with softened or unsoftened water.)

This humidifier is designed for use with either softened or unsoftened water (preferably softened). The probe-type level control system requires water conductivity of 100 micromhos/cm (2 grains/gal) minimum to function, and therefore will not operate on water treated by reverse osmosis or deionization. However, STS humidifiers are available for use with these water types. The standard humidifier can be converted in the field to a STS-DI model. See below.

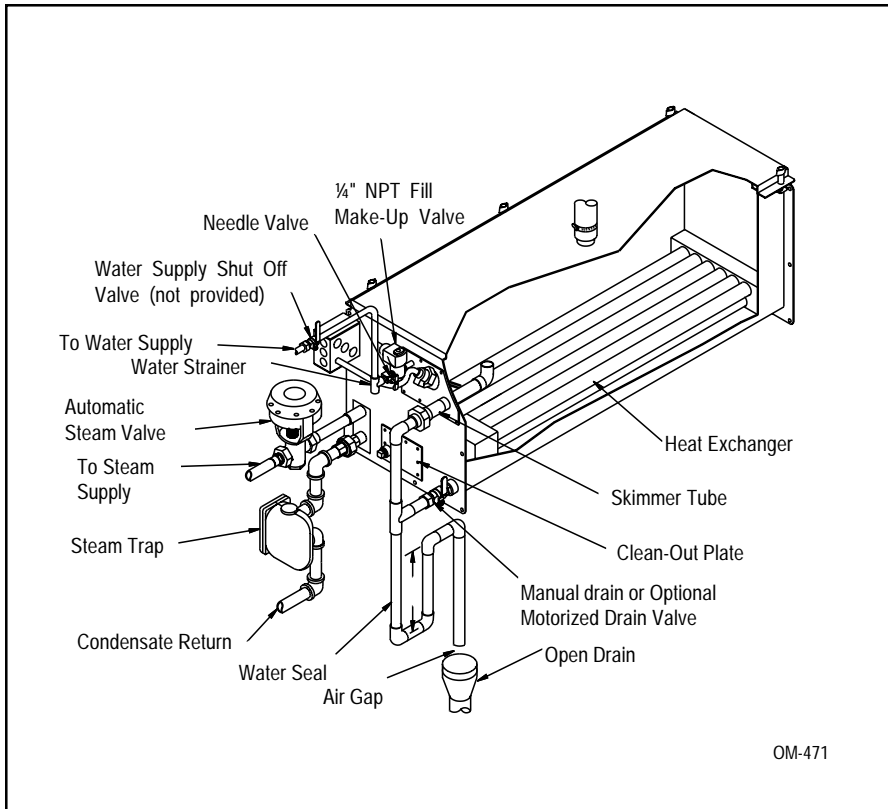

STS-DI Humidifier (For use with demineralized or reverse osmosis water.)

For use with deionized or reverse osmosis water. This unit produces chemical-free steam and reliable, accurate humidification control. It is virtually maintenance-free, with no wasted water, heat, or downtime.

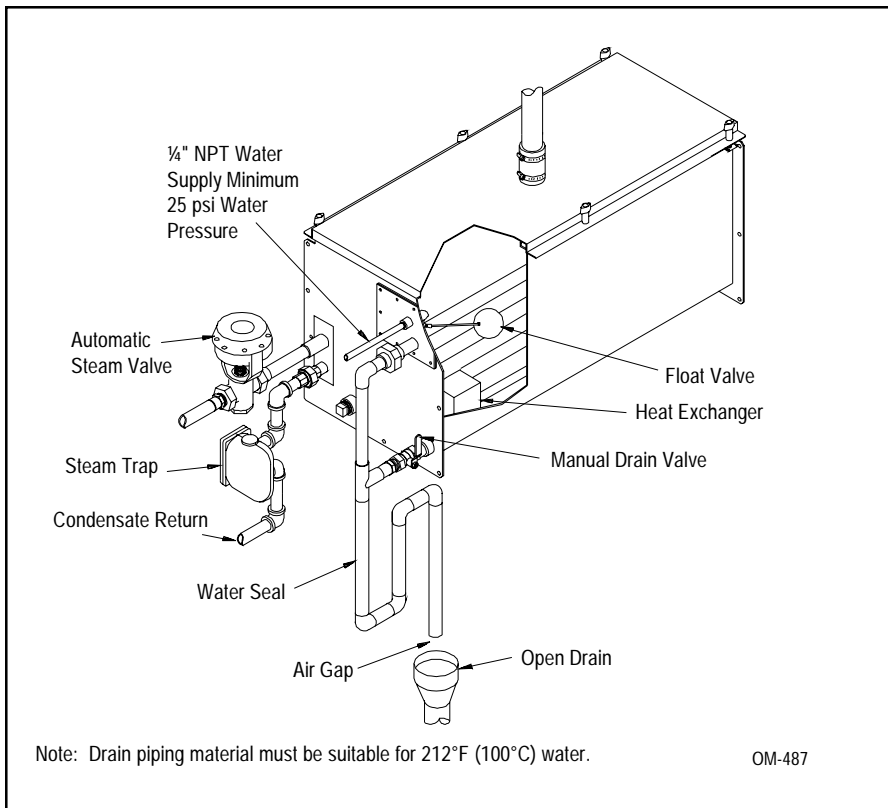

CAPACITIES AND DIMENSIONS

Table 4-1: Mechanical dimensions for STS and STS-DI units with stainless steel heat exchanger(s)

Description	STS-25S		STS-50S		STS-100S		STS-200S		STS-400SNC		STS-800SNC	
	in.	mm	in.	mm	in.	mm	in.	mm	in.	mm	in.	mm
A Overall height	18.25	465	18.25	465	18.25	465	18.25	465	18.25	465	28.57	725
B Face width	14.75	375	14.75	375	19.25	490	28.25	720	28.25	720	28.25	720
C Face length	23.68	600	39.68	1010	39.68	1010	55.21	1400	55.21	1400	55.21	1400
D Distance from bottom to supply inlet	6.85	175	6.85	175	6.85	175	6.85	175	6.85	175	6.85	167
E Distance from bottom to return outlet	3.35	85	3.35	85	3.35	85	3.35	85	3.35	85	3.35	85
F Distance from bottom to supply inlet of second heat exchanger	--	--	--	--	--	--	--	--	--	--	14.50	360
G Distance from bottom to return outlet of second heat exchanger	--	--	--	--	--	--	--	--	--	--	11.00	285
H Distance from side to heat exchanger	3.25	83	3.25	83	3.25	83	3.25	83	3.25	83	3.25	83
J Supply inlet	"NPT (DN 20)	--	1"NPT (DN 25)	--	1"NPT (DN 25)	--	1½"NPT (DN 40)	--	1½"NPT (DN 40)	--	1½"NPT (DN 40)	--
K Return outlet	"NPT (DN 20)	--	"NPT (DN 20)	--	"NPT (DN 20)	--	"NPT (DN 20)	--	"NPT (DN 20)	--	"NPT (DN 20)	--

Table notes:
 S= Stainless steel
 SNC= Stainless steel without Teflon coating
 For use with DI/RO water only

Table 4-2: Mechanical dimensions for STS and STS-DI units with copper heat exchanger(s)

Description	Model number									
	STS-25C		STS-50C		STS-100C		STS-400C		STS-800C	
	in.	mm	in.	mm	in.	mm	in.	mm	in.	mm
A Overall height	18.25	465	18.25	465	18.25	465	18.25	465	28.57	725
B Face width	14.75	375	14.75	375	19.25	490	28.25	720	28.25	720
C Face length	23.68	600	39.68	1010	39.68	1010	55.21	1400	55.21	1400
D Distance from bottom to supply inlet	6.63	170	6.63	170	6.63	170	6.63	168	6.63	168
E Distance from bottom to return outlet	3.59	90	3.59	90	3.59	90	3.59	90	3.59	90
F Distance from bottom to supply inlet of second heat exchanger	--	--	--	--	--	--	--	--	14.28	362
G Distance from bottom to return outlet of second heat exchanger	--	--	--	--	--	--	--	--	11.24	285
H Distance from side to heat exchanger	3.25	83	3.25	83	3.25	83	3.25	83	3.25	83
J Supply inlet	"NPT (DN 20)	--	"NPT (DN 20)	--	1..."NPT (DN 32)	--	1..."NPT (DN 32)	--	1..."NPT (DN 32)	--
K Return outlet	"NPT (DN 20)	--	1..."NPT (DN 32)	--	1..."NPT (DN 32)	--	1½"NPT (DN 40)	--	1½"NPT (DN 40)	--

Table notes:
 C= Copper

Table 4-3: Capacities for units with stainless steel heat exchangers

Model number	Output capacities with stainless steel heat exchangers							
	* Steam pressure PSI (kPa)							
	PSI	kPa	PSI	kPa	PSI	kPa	PSI	kPa
	5	34	10	69	13	90	15	103
STS-25S	10 pph	5 kg/h	25 pph	11 kg/h	30 pph	14 kg/h	35 pph	16 kg/h
STS-50S	30 pph	14 kg/h	55 pph	25 kg/h	75 pph	34 kg/h	80 pph	36 kg/h
STS-100S	60 pph	27 kg/h	110 pph	50 kg/h	140 pph	64 kg/h	150 pph	68 kg/h
STS-200S	150 pph	68 kg/h	290 pph	132 kg/h	360 pph	163 kg/h	390 pph	177 kg/h
**STS-400SNC	170 pph	77 kg/h	392 pph	178 kg/h	552 pph	250 kg/h	637 pph	289 kg/h
**STS-800SNC	212 pph	96 kg/h	825 pph	374 kg/h	1095 pph	497 kg/h	1223 pph	555 kg/h

Table 4-4: Capacities for units with copper heat exchangers

Model number	Output capacities with copper heat exchangers							
	* Steam pressure							
	PSI	kPa	PSI	kPa	PSI	kPa	PSI	kPa
	5	34	10	69	13	90	15	103
STS-25C	20 pph	9 kg/h	70 pph	32 kg/h	100 pph	45 kg/h	120 pph	54 kg/h
STS-50C	50 pph	23 kg/h	150 pph	68 kg/h	200 pph	91 kg/h	240 pph	109 kg/h
STS-100C	100 pph	45 kg/h	300 pph	136 kg/h	400 pph	181 kg/h	480 pph	218 kg/h
STS-400C	300 pph	136 kg/h	580 pph	263 kg/h	720 pph	327 kg/h	790 pph	358 kg/h
STS-800C	650 pph	295 kg/h	1275 pph	578 kg/h	1500 pph	680 kg/h	1600 pph	726 kg/h

Table 4-3 and 4-4 notes:
 * Steam pressure at connection to the STS steam valve (provided by DRI-STEEM)
 ** SNC = Stainless No (Teflon) Coating. For use with DI/RO water only.

CAPACITIES AND DIMENSIONS

STS and STS-DI® all sizes

Side view

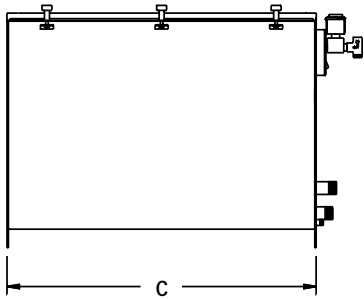

Table 5-1: Humidifier weights

Model number	Operating weight		Shipping weight	
	lbs	kg	lbs	kg
STS-25	175	79	95	43
STS-50	336	152	125	57
STS-100	350	159	139	63
*STS-200	850	386	245	111
*STS-400	950	431	320	145
*STS-800	1450	658	410	186

Table 5-1 note:

*Suspending from overhead construction is not recommended due to operating weight of unit.

STS and STS-DI (single heat exchanger) sizes 25S&C, 50S&C, 100S&C, 200S, 400C, and 400SNC

Front view

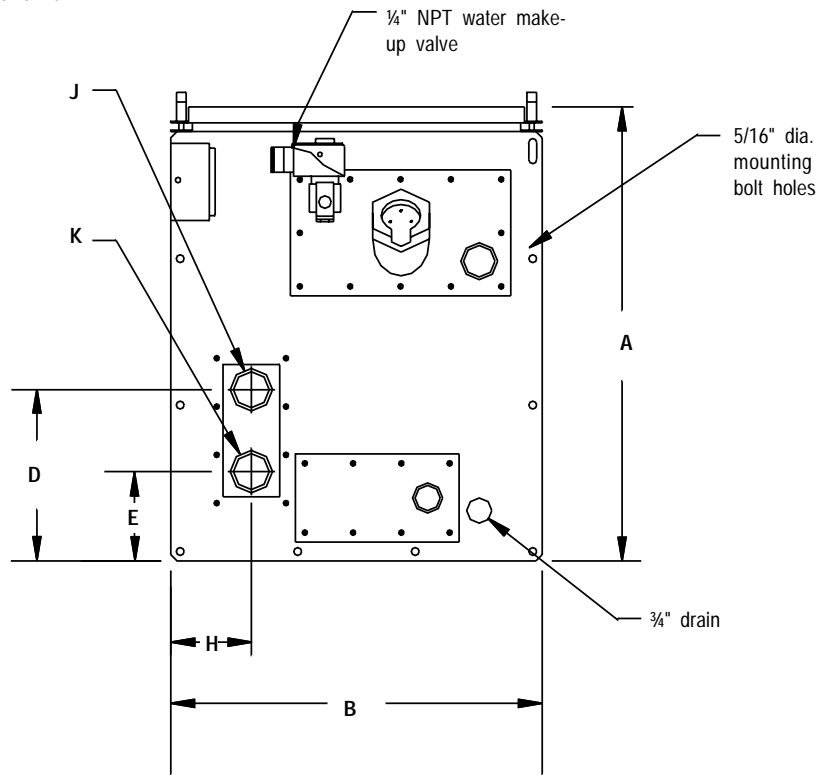

STS and STS-DI (dual heat exchanger) size 800C and 800 SNC

Front view

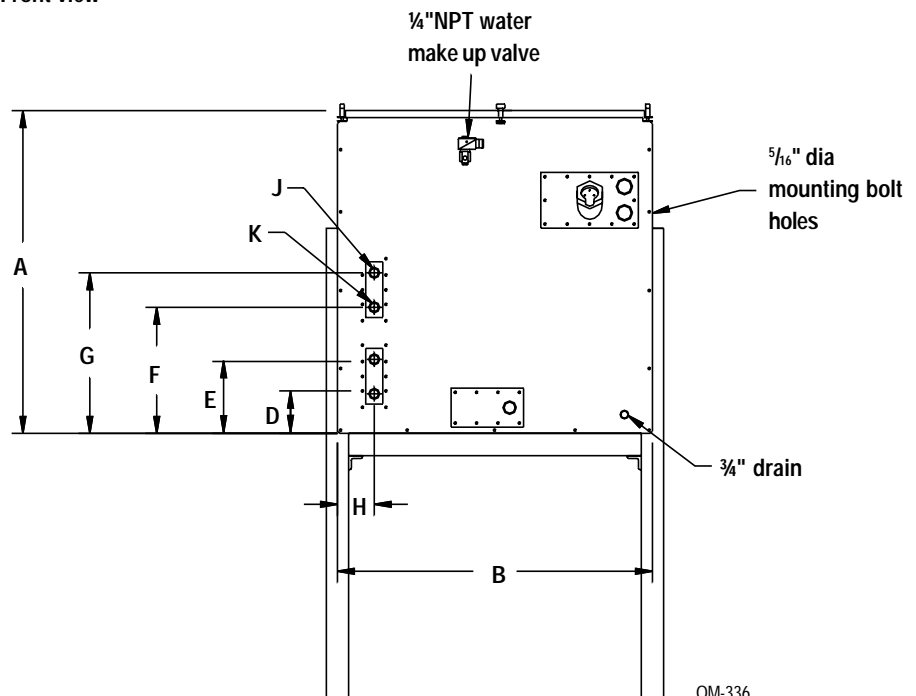

Note:

See Tables 4-1 and 4-2 (page 4) for dimensional data.

MOUNTING METHODS

Mounting Notes

1. For the electrode probe water level control and the skimmer system to properly operate, the humidifier must be mounted level in both directions.
2. Access (12" to 18" minimum) for periodic removal of the top cover is recommended. In most cases, scale that forms on the heat exchanger continuously flakes off as it

forms and the loose scale settles to the bottom. A clean-out tray on the floor of the evaporator may be removed periodically through the front clean-out opening.

3. Due to the size and weight of the STS® 200, 400 and 800 units, the trapeze hanger and wall brackets are not recommended.

Figure 6-1: STS Mounting Options

1. Floor Stand

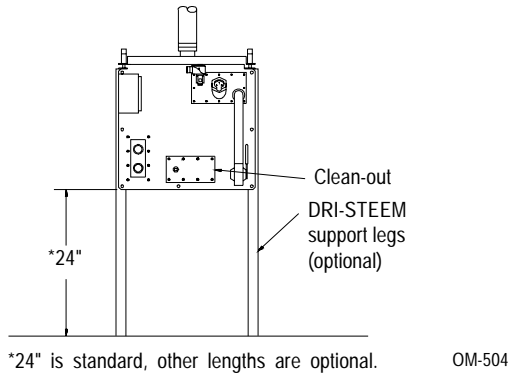

2. Trapeze Hanger (see note 3 above)

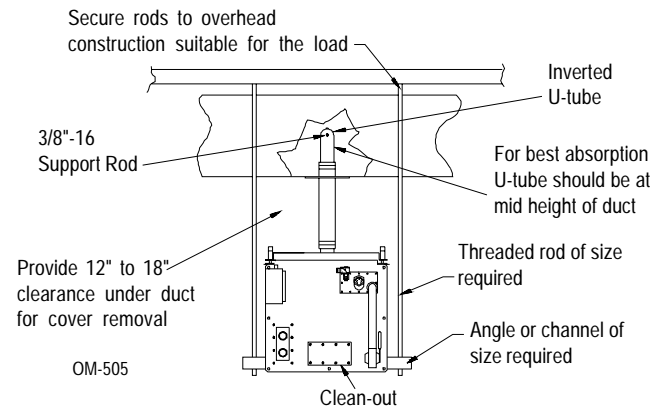

3. Wall Brackets (see note 3 above)

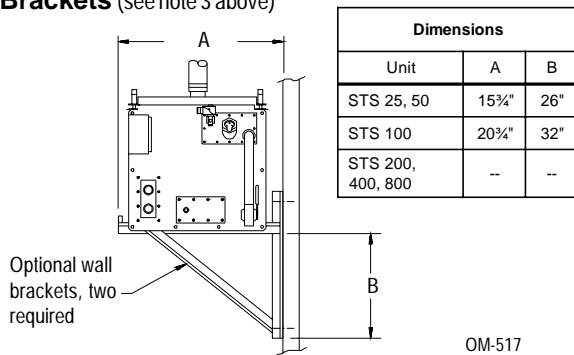

4. Cradle

Models STS 200, STS 400C and 800C require cradle.

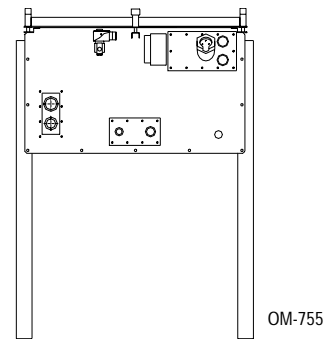

5. Mounting STS Unit on Underside of Duct

Mounting humidifier 12" to 18" below duct recommended to facilitate cover removal.

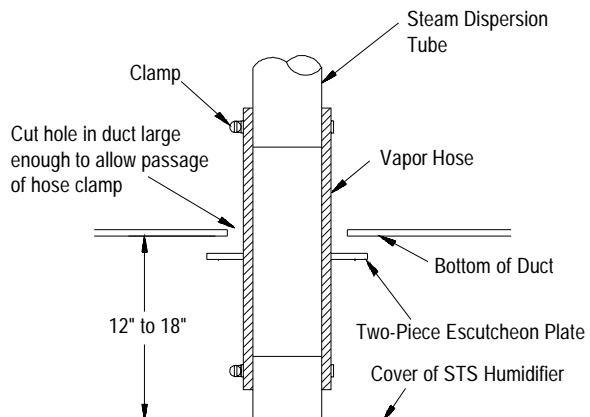
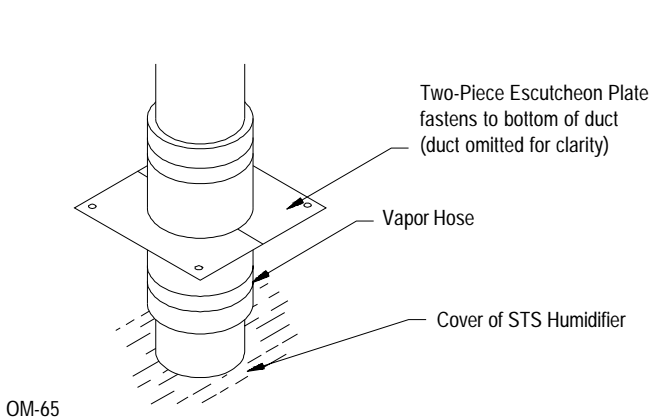

MOUNTING METHODS

6. Mounting STS Unit Away from Duct(s) Using Vapor Hose

Vapor hose. (Pitch back min. 2" per foot to humidifier with supports to prevent pockets.) Maximum length 10'. Humidifier must be mounted level.

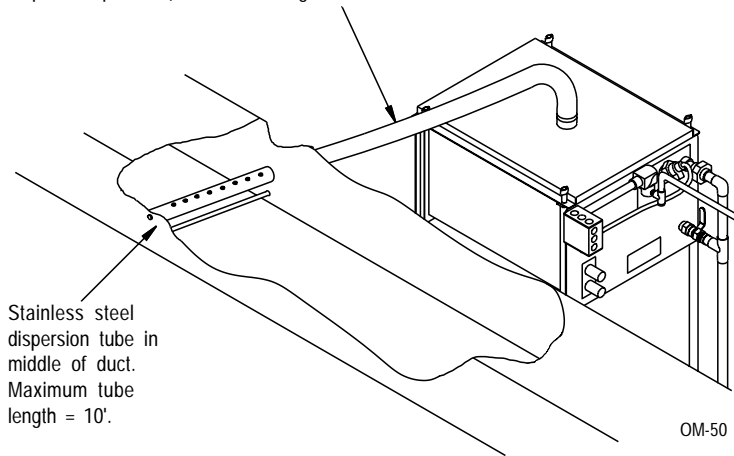

7. Mounting STS in Air Handling Unit (with U-Tubes)

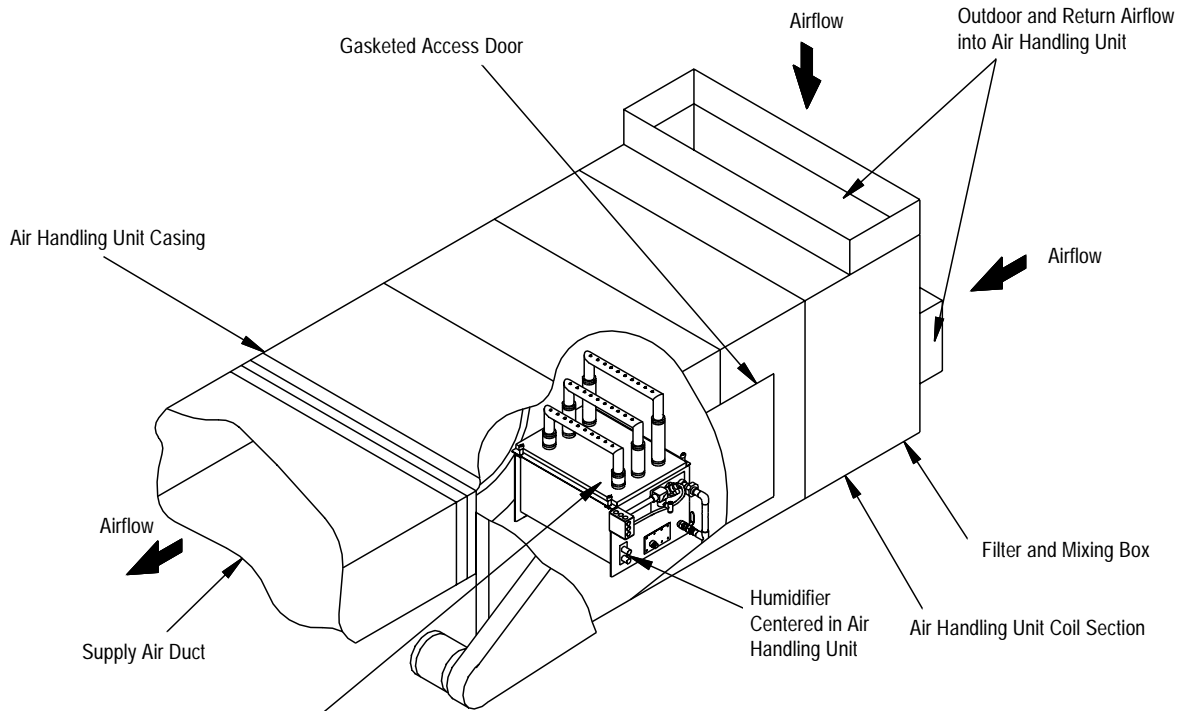

Set unit level. Locate unit so that steam dispersion assembly is in the most active part of the air stream.

OM-276

PIPING

Steam Supply

The heat exchanger in the STS® standard humidifier is designed for a maximum steam pressure of 15 psi. The steam valve, trap and strainer are shipped loose for field installation.

Make-up Water Piping

Either cold or hot water can be used for make-up. The water pressure must be between 25 to 100 psi. If the water pressure is above 60 psi and/or water hammer would be objectionable, a pressure reducing valve or shock arrester should be installed. Even though the STS has an inner 1" air gap, some local codes may require a vacuum breaker in the water supply pipe.

Make-up Water Considerations

When non-metallic water piping is used, it must be rated to withstand 212°F or greater temperature. If not, the final 3 feet connected to the humidifier should be metallic and should not be insulated.

As part of the fill valve assembly, a needle valve is provided. It restricts the rush of cold water entering the evaporating chamber during each fill cycle. The needle valve adjusted to minimize output disruption and potential "water hammer" (water pressure must be between 25 and 100 psi).

The STS Humidifier works with all water types - potable, softened or demineralized make-up water.

Preferably this humidifier should be supplied with softened water. The probe type level control system requires water conductivity of 100 micromhos/cm (2 gr/gal) minimum to function and will not operate with water treated by reverse osmosis or deionizing process. Specially designed STS DI humidifiers are available for use with these water types.

Softened Water

There are two major advantages derived from using softened water instead of potable water (assuming the untreated supply water hardness is over 10 grains per gallon): maintenance and accuracy of control.

Maintenance

The skimmer, in conjunction with softened water, is an unbeatable combination for eliminating scale formation in the evaporating chamber. Several seasons of operation with no need for cleaning is normal, even with water having up to 30 grains of dissolved minerals per gallon prior to being softened.

Accuracy of Control

Reducing the higher skimmer quantity and eliminating the drain/flush cycle (both of which are accomplished by the use of softened water) improves controllability.

Softened Water Reduces Water Usage

The fewer number of make-ups per unit of time and the lesser the amount of water per make-up, the more "on time" or actual humidifying time will occur thus improving control accuracy. This is especially true when modulating control of the steam input to the humidifier is used.

Figure 8-1:

This piping method is recommended when obstruction prevents dispersion tube from being continuously pitched back to the humidifier.

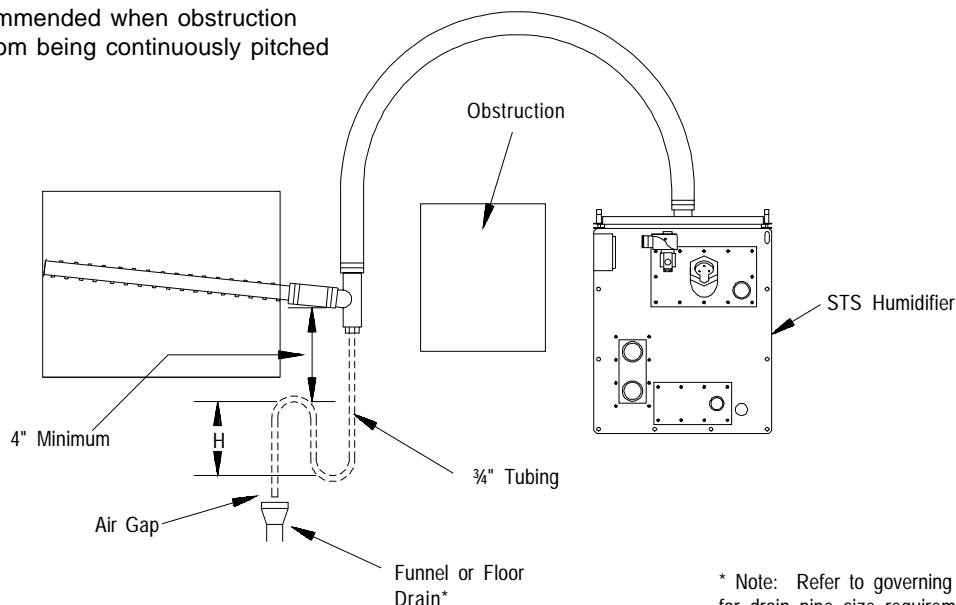

OM-702

* Note: Refer to governing codes for drain pipe size requirements.

PIPING

Potable Water

For water less than 10 grains per gallon hardness the skimmer system alone, without softening, usually provides a full season or more of humidification without a need for cleaning the evaporator.

For water hardness above 10 grains per gallon and where softened water is not available the timer operated drain/flush feature is available. The humidifier control module contains an integral adjustable timer which accumulates the "on" or actual humidifying time of the unit. When this accumulated time reaches the amount previously pre-set in the control module, the drain/flush cycle is activated.

Drain Piping

A drain line should be extended from the skimmer/drain connection to a sanitary waste. A **water seal should be provided** in the drain line of sufficient height to contain the pressure developed within the humidifier. Without this, steam will be forced through the drain line which would be objectionable. The depth of the water seal must be sufficient to overcome the static pressure of the air handling system plus the pressure developed by the humidifier itself. (Refer to table 11-1 on page 11.)

Figure 9-1: This piping method is recommended when humidifier must be mounted higher than the duct.

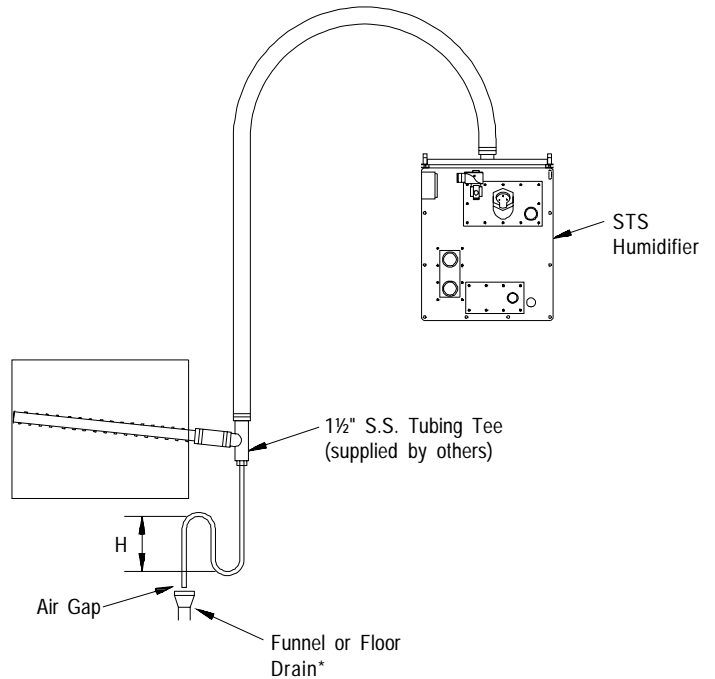

OM-703

* Note: Refer to governing codes for drain pipe size requirements.

PIPING

Figure 10-1 - Piping of STS® from an overhead steam supply main with condensate returned to a vented gravity flow return system. Note the steam trap installed at the bottom of the branch rise feeding the steam valve of the STS. Failure to install this trap will cause water hammer, which could damage the STS heat exchanger.

Figure 10-2 - Depicts the same supply configuration, however the condensate return main is above the STS and the condensate must be "lifted". Lifts in excess of six inches per PSI steam inlet pressure should not be attempted. Check valves downstream of both steam traps are necessary to avoid hammer and associated problems.

In both instances, Figure 10-1 and 10-2, vacuum breakers are necessary to ensure condensate can drain from the heat exchanger when the steam valve closes.

Figure 10-1

Figure 10-2

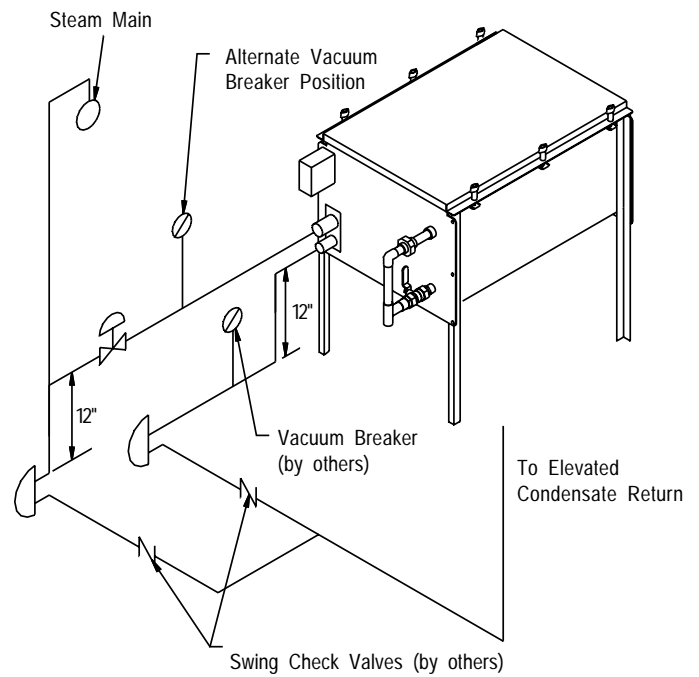
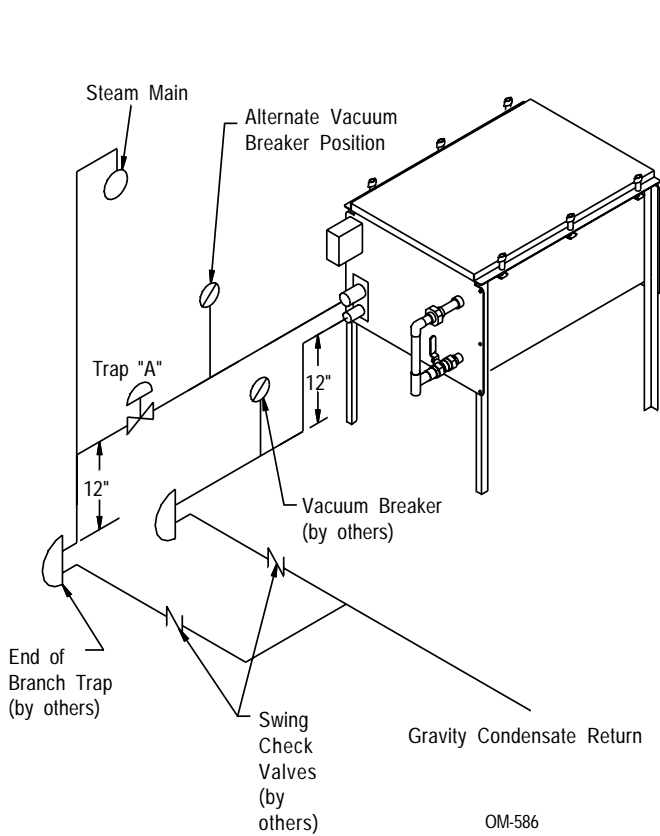

OM-586

OM-586

PIPING DIAGRAMS: STEAM, WATER AND DRAIN

Figure 11-1: Standard STS®

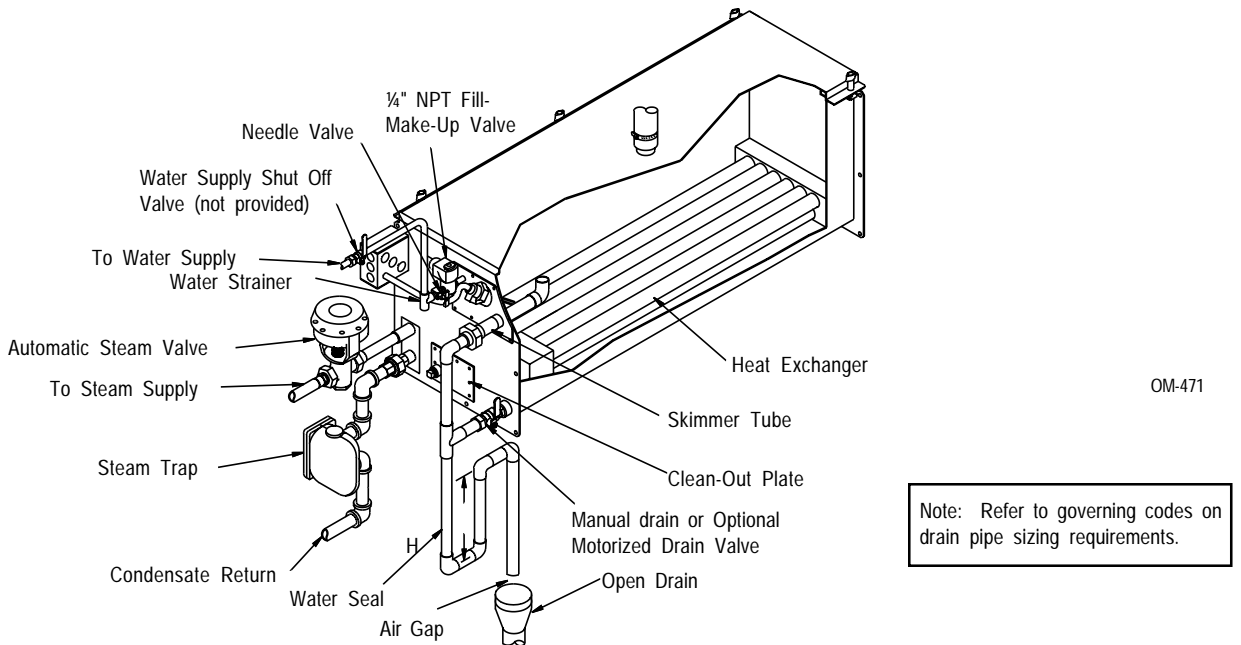
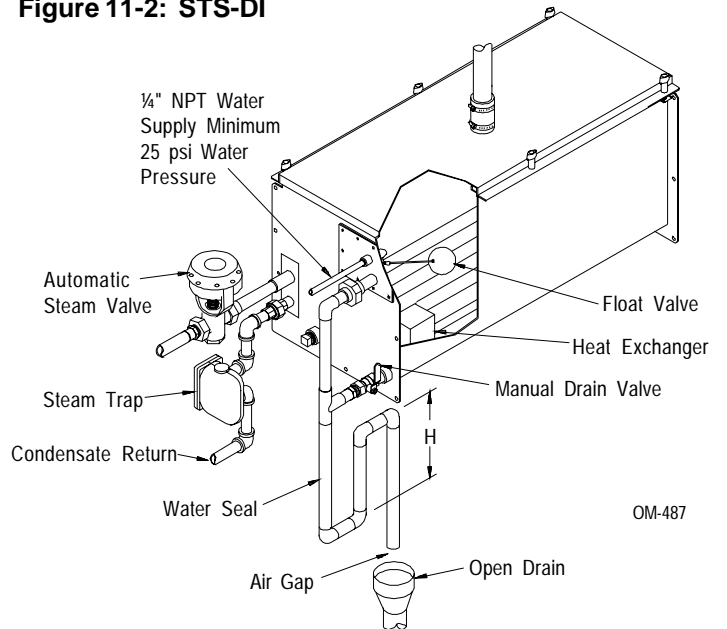

Table 11-1: Water Seal Height Recommendations

Water Seal Height (H)	
Unit Output (pounds per hour)	H (inches)
5-138	12
139-183	15
184 and higher	18

Figure 11-2: STS-DI



Note: Drain piping material must be suitable for 212°F (100°C) water.

PIPING DIAGRAMS: STEAM, WATER AND DRAIN

Figure 12-1: Alternate Water Seal and Valve Piping

Used when water seal must be elevated above flow line of drain connection (Humidifier near floor). Water seal height recommendations refer to table 11-1.

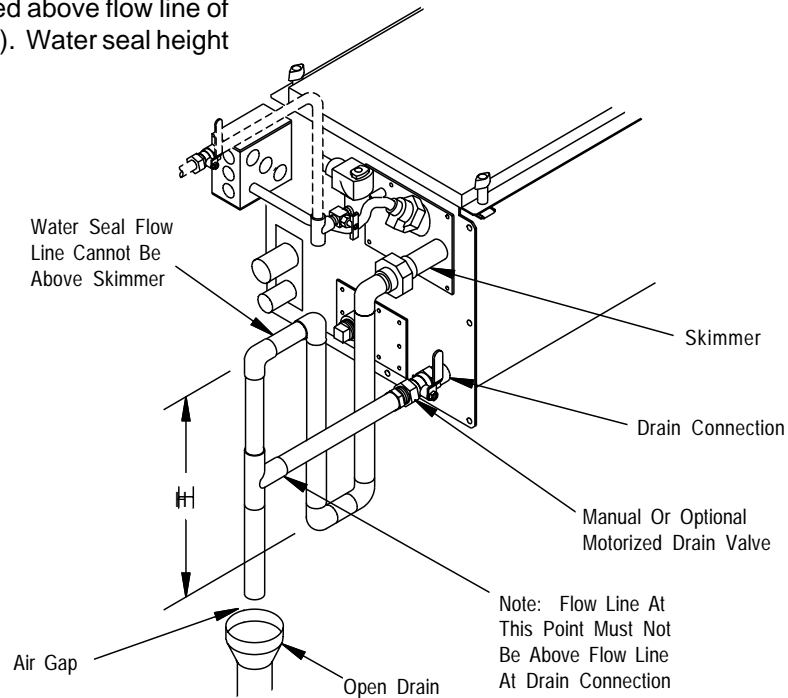

ELECTRICAL

The electrical supply is 120 volt, single phase. The control cabinet should be mounted in a location for service. All wiring must be in accordance with all governing codes and the STS[®] wiring diagram. A wiring diagram is inside the control cabinet. The wiring between the control cabinet and the humidifier must be 105°C rated wire.

Please refer to the VAPOR-LOGIC₂ O&M for electrical connection information on the controller.

Caution: Only qualified electrical personnel should perform installation and start-up procedures.

STEAM DISPERSION INSTALLATION

STS Dispersion Tube Installation with Condensate Drain

Vapor Hose

- Vapor hose should be supported to prevent sags or low spots and to maintain a minimum pitch of 2" per foot back to the humidifier.
- When mounting the humidifier above the level of dispersion tube, see page 9.

Failure to follow the above recommendation may result in excessive back pressures being imposed on the humidifier. This in turn may lead to dispersion tube(s) spitting, lost water seals or leaking gaskets. When distance between humidifier and the dispersion tube(s) exceeds 10 feet, consult factory for special recommendations.

Hard Piping

- Hard piping should have a minimum I.D. of 1½".
- A minimum pitch of 2" per foot back to the humidifier should be maintained.
- 90° elbows are not recommended, use two 45° elbows one foot apart instead.
- Thin wall tubing will heat up faster and cause less start up loss than heavy wall pipe.
- Insulating the hard piping will reduce the loss in output caused by condensation.

Tube Mounting

- Mount dispersion tube level.
- Best vapor absorption occurs when dispersion tube discharges against the air flow.

**Return line piping material must be suitable for 212° F (100°C) water.

Minimum Condensate Drain Line Sizing

- One or two tubes: ¾" I.D.
- Three or more tubes - 1" I.D.

Figure 13-1: Single Tube

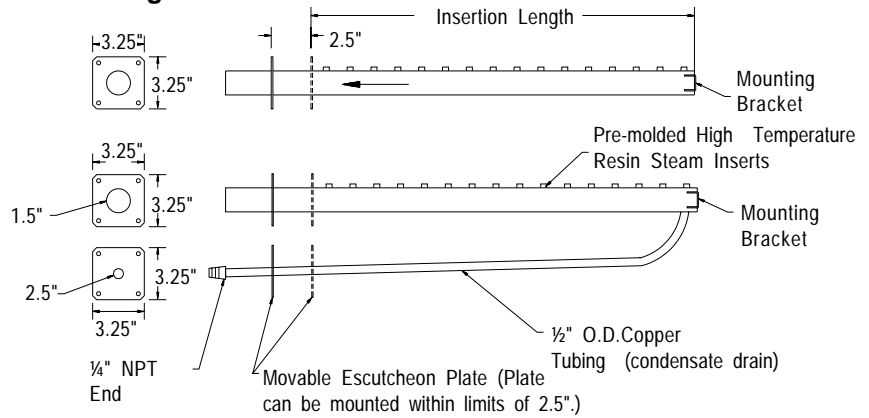

OM-351

Figure 13-2: Multiple Tube with Condensate Wasted to Floor Drain

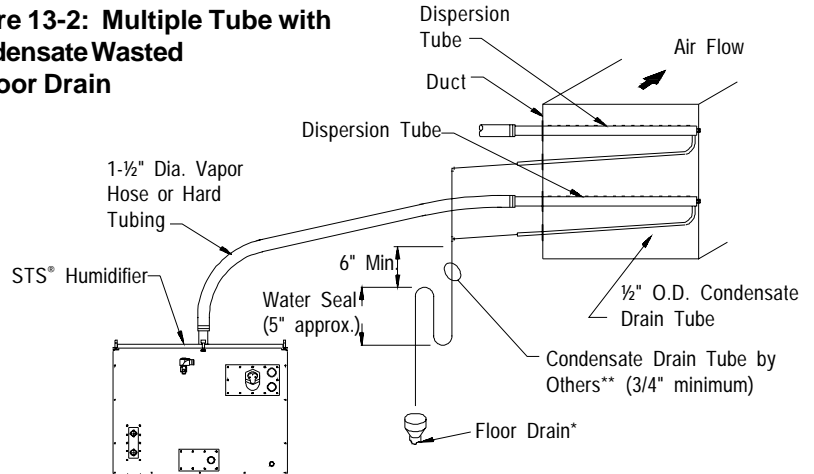

OM-1020

* Note: Refer to governing codes for drain pipe size requirements.

Figure 13-3: Multiple Tube with Condensate Return to Humidifier

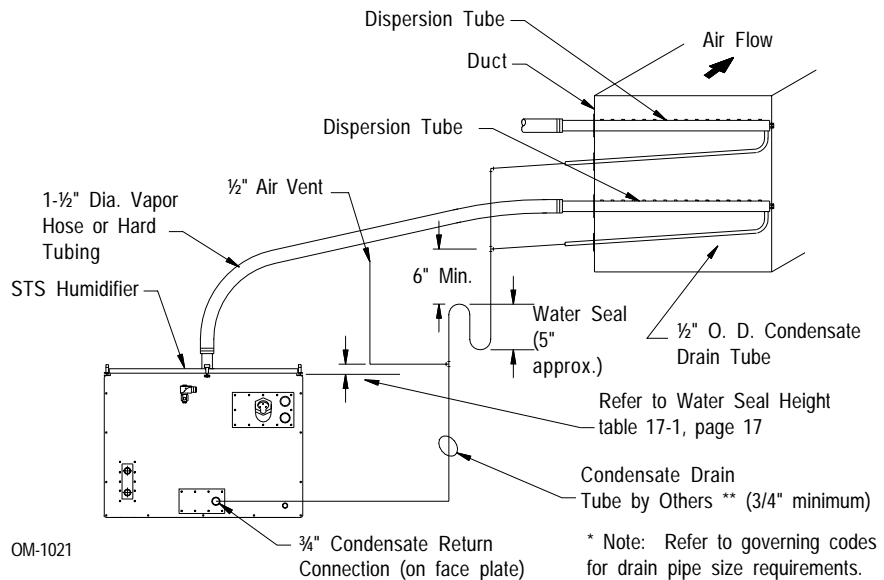

OM-1021

* Note: Refer to governing codes for drain pipe size requirements.

STEAM DISPERSION INSTALLATION

Selecting the Location:

- A. It is very important that the dispersion method be located where the water vapor being discharged will be carried off with the airstream and will not cause condensation or dripping from the duct.
- B. In general, the dispersion method is best placed where the air can most readily absorb the moisture being added without causing condensation at or after the unit. This will normally be after the heating coil or where the air temperature is highest.
- C. Do not place the dispersion method too close to the intake of a high efficiency filter. The filter may remove the visible moisture and become water-logged.*
- D. Do not place dispersion method where water vapor will impinge on a metal surface.
- E. Do not place the dispersion method too close to a split in the duct. The unit may put more moisture in one branch than the other.

Installation Above Valuable Equipment

Water piping and humidifiers should not be installed above expensive apparatus or equipment. The risk of a broken water pipe, leaking valve gland, condensation or other water leaks may occur causing serious damage and costly repairs to the equipment below.

Where this type of installation cannot be avoided install a drip tray constructed of galvanized sheet under the humidifier, valve, etc. to catch any possible water drip.

It is advisable to terminate the drain above an open floor drain. The overflow from the STS® should be piped separately to a floor drain rather than the drip pan.

Figure 14-1: Installation Above Valuable Equipment

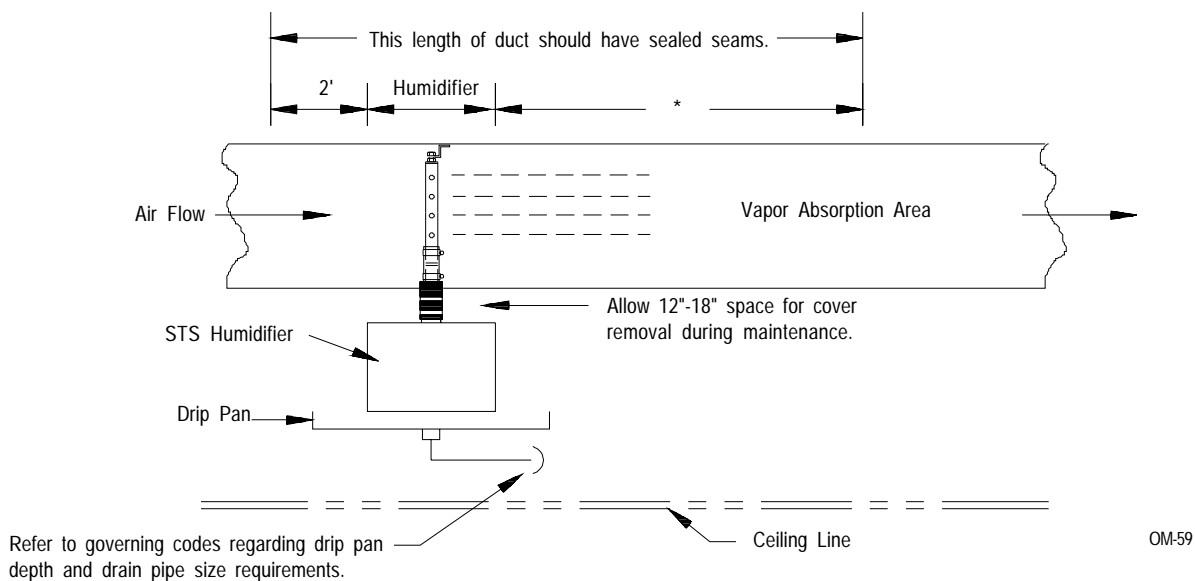

* The distance steam will travel within a given airstream is predictable and can be determined using the STS catalog. If this has already been done, the travel distance should be specified; if not, consult the STS catalog or contact you DRI-STEEM representative or the DRI-STEEM factory.

RAPID-SORB® ASSEMBLY AND INSTALLATION

Horizontal Duct Installation

1. Unpack Shipment and verify receipt of all RAPID-SORB components with packing list. Report any shortages at once to the DRI-STEEM factory.
2. Provide necessary access around and into duct work.
3. Locate 1" x 1½" stainless steel channel inside duct centered between duct side walls. Hang channel from top of duct with the two mounting holes provided.
4. Locate dispersion tubes and slide hose cuffs over end of each tube, include a pair of hose clamps.
5. Note direction of air flow within duct then arrange each dispersion tube so steam will blow perpendicular to the air flow. Use the hex bolts provided to attach tubes to overhead 1" x 1½" channel. Do not secure. On units with the header mounted outside the duct, punch-out necessary clearance holes in base of duct to slide dispersion tubes up from bottom (see figure 15-2).

6. For a Header Inside the Duct (See figure 15-1.): Punch or cut out necessary clearance holes for RAPID-SORB header. Slide header into the duct, position header and slide the dispersion tube hose cuffs or slip couplings over the header dispersion tube nipples.

Position the header so vertical dispersion tubes are perpendicular to duct and pitch the header toward condensate drain. Secure header to the mounting bracket. Use escutcheon plates to secure header where it enters the duct.

Check that the dispersion tubes release steam perpendicular to the air flow. Secure tubes to the overhead channel. Secure the channel to the duct, and secure hose cuffs or slip couplings over tube and header tube nipples.

For a Header Outside the Duct (see figure 15-2.): Position header under dispersion tubes, then slide hose cuffs or slip couplings over header dispersion tube nipples.

Position the header so dispersion tubes are perpendicular to duct and pitch the header to condensate drain. Secure dispersion tubes in place with the tube escutcheon plates provided.

Check the position of the tubes for steam release perpendicular to the air flow. Secure tubes to the overhead channel, and secure channel to the duct. With header pitched to condensate drain, slip hose cuffs or slip couplings over tube nipples and secure.

7. Connect a condensate drain to header, provide the water trap as shown and run to open drain, sized per governing codes.

8. Attach the header swivel hose connector to main header using the hose cuff and clamps provided, do not secure.

9. Route the necessary number of vapor hoses or pipes from the humidifier tank, position connector to accept the hoses or pipes and secure.

Note: Refer to page 10 for vapor hose information on routing and for alternate vapor hose installation methods.

Figure 15-1: RAPID-SORB Unit Header Inside Duct

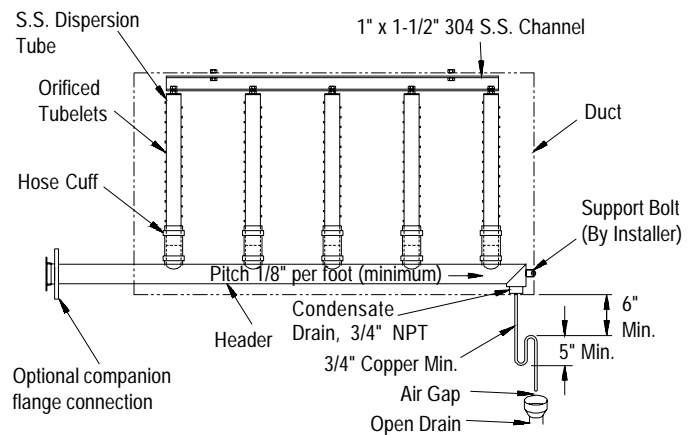
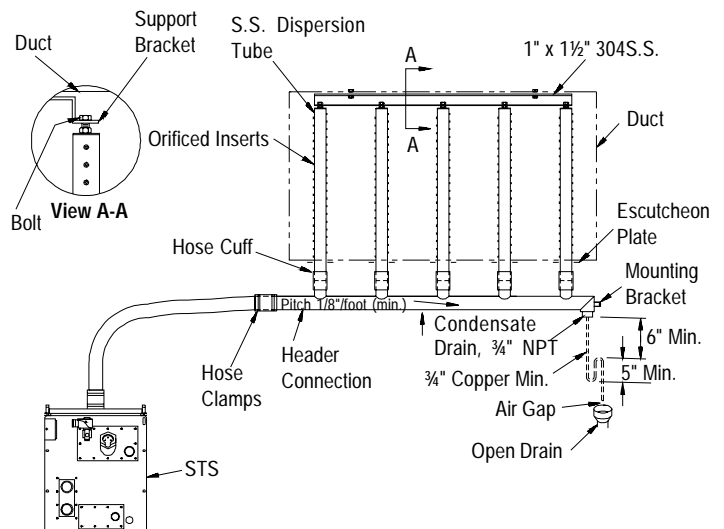

Figure 15-2: RAPID-SORB Unit Header Under Duct



RAPID-SORB® ASSEMBLY AND INSTALLATION

Vertical Duct Installation

Install the RAPID-SORB® with dispersion tubes and header pitched to condensate drain as shown in figures 16-1, 16-2, and 16-3.

Figure 16-1: Plan View

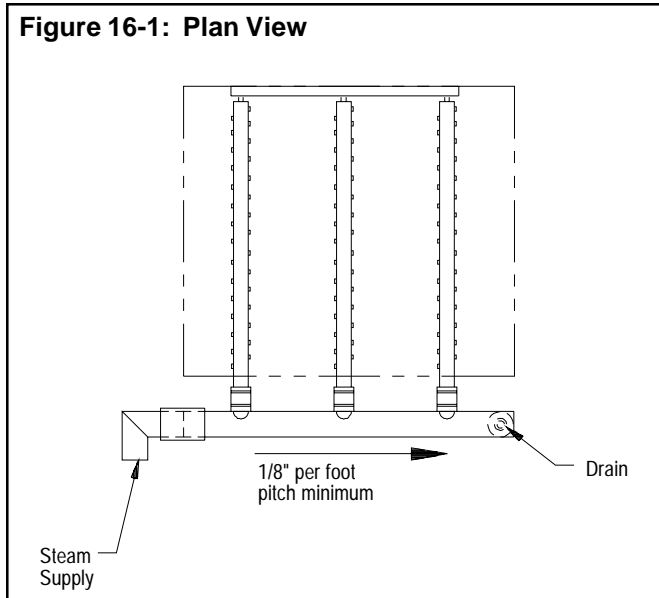

Figure 16-2: Elevation View Tube without Drain

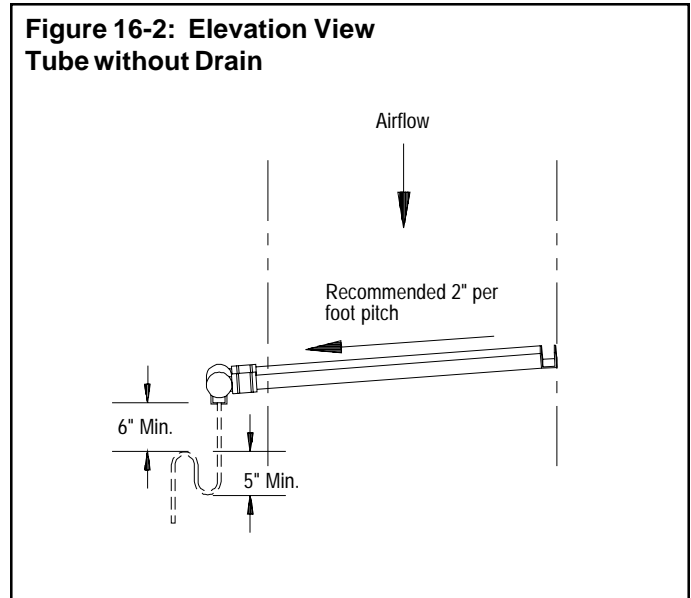

Figure 16-3: Elevation View Tube with Drain

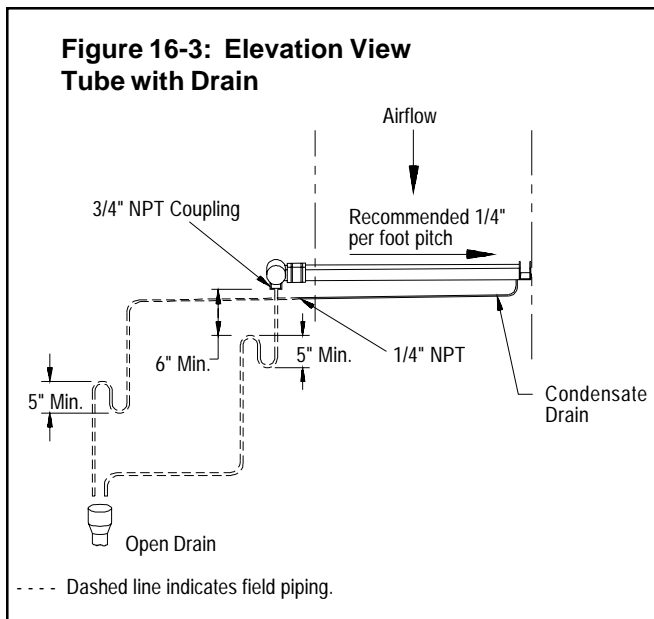

Table 16-1*: Maximum Steam Carrying Capacity in Lbs/Hr and Kg/Hr

Vapor Hose			Copper or Stainless Steel Tubing and Schedule 40 Steel Pipe		
Hose I.D.	Developed Length of 10' (3.0 Meters)**		Tube or Pipe Size	Base on Developed Length of 20' (6 Meters)**	
1 1/2" (38 mm)	150 lbs/hr	68 kg	1 1/2" (38 mm)	150 lbs/hr	68 kg/h
2" (50 mm)	250 lbs/hr	115 kg	2" (50 mm)	220 lbs/hr	100 kg/h
			3" (75 mm)	450 lbs/hr	205 kg/h
			4" (100 mm)	750 lbs/hr	340 kg/h
			5" (125 mm)	1400 lbs/hr	635 kg/h
			6" (150 mm)	2300 lbs/hr	1043 kg/h

* Based on total pressure drop in piping/hose of 5" (12.65 mm) W.C.
 ** For developed length add 50% to measured length for pipe fittings.
 Note: To minimize loss of humidifier capacity and efficiency, it is recommended that tubing/piping be installed.

START-UP AND OPERATION

Figure 17-1: Reliable Electronic Probe Control Maintains Water Level

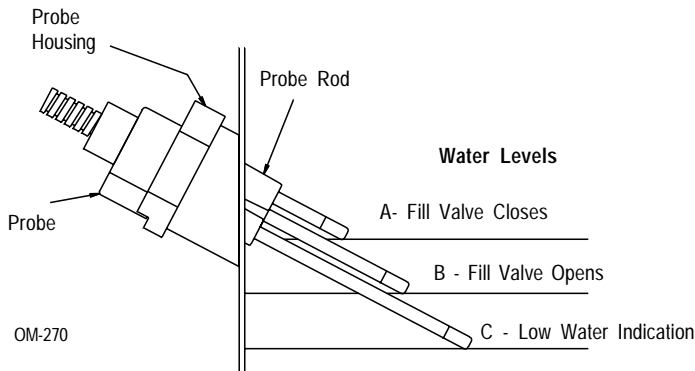

A simple three-probe conductivity sensor cycles a solenoid-operated water fill valve to maintain the proper water levels.

The STS® humidifier is provided with a standard VAPOR-LOGIC₂ microprocessor control system, see the VAPOR-LOGIC₂ *Installation and Operations Manual* for more information. Then continue reading this manual beginning at the maintenance section on page 20.

Water Control with VAPOR-LOGIC₂

When the power is activated the solenoid-operated water fill valve will open, filling the evaporating chamber. Filling will continue until water reaches level A, at which time the fill valve will close. To ensure that the water seal is filled with water, disconnect probe plug and cable from probe rod assembly (located on face plate), allowing the fill valve to re-energize and overfill humidifier tank. This process will take only seconds; probe plug and cable must then be reconnected.

Water Refill

During operation, the water line will drop to level B. At this level the fill valve opens, and remains open until the water line returns to level A.

Adjustable Surface Skimmer

Each time the evaporating chamber refills, the upper ¼" of water is immediately drained off through the skimmer. This carries away the mineral residue formed during the previous evaporating cycle. This skimming action effectively removes most of the mineral concentration in much the same way as the surface blowdown does in a steam boiler. This simple device greatly reduces the frequency of cleaning the evaporating chamber.

Note: Preferably this humidifier should be supplied with softened water. However, the probe type level control system requires water conductivity of 100 micromhos/cm (2 grains/gal) minimum to function and may not operate in water treated by the reverse osmosis or deionizing process. Specially designed STS Model DI humidifiers are available for use with these water types.

RECOMMENDED MAINTENANCE

Caution: Allow unit to cool before performing any maintenance. Manually open the drain valve and the fill valve will be energized. Let the fill water run until the tank is cooled then shut off the contractor/field installed supply water valve.

STS® is designed to deal with dissolved minerals in one of two ways depending on the degree of hardness. For light to moderate hardness (up to 10 grains per gallon) the surface skimmer action plus periodic cleaning is usually adequate. For high mineral content water (above 10 grains per gallon) a periodic drain and flush along with periodic cleaning may be helpful.

The frequency of cleaning will be dictated by water condition and evaporation load.

Caution: *When performing maintenance on the STS always turn off electric power to control panel. Close steam supply and water make-up valves.*

Seasonally or as Required

1. Cleaning Tank

Remove loose scale in humidifier tank before the build-up reaches the underside of the heat exchanger(s).

2. Cleaning Probes

Remove cap assembly and unscrew the probe holder from the STS unit. The scale will easily flake off from the sensing probes. The sensing portion (bottom 3/8") of the probe should be brushed clean with stainless steel wool. Re-install the probe holder with arrows up and "top" marking at the top.

3. Cleaning Skimmer Tube

Remove the elbow section of the skimmer and rotate tube so that loosened material will drop out. Loosen deposits with a long tool such as a screwdriver or section of small diameter pipe and reassemble elbow. Skimmer drainage should be verified by visual inspection once per week. Water should drain from skimmer drain pipe after each fill cycle. (For cleaning piping, disconnect and flush out. If mineral deposits have restricted the flow, replace piping.)

4. Inspect Gaskets

Replacement procedures are provided with new gaskets.

Summer Maintenance

After the humidification season, a complete inspection and cleaning of the heat exchanger, probe control, skimmer, and water chamber is recommended. After cleaning, the unit should remain empty until humidification is required.

On units with TEFLON® coated heat exchangers, do not use a sharp object when cleaning. Cuts or scratches on the heat exchanger will impair its ability to shed scale during operation, and could cause the TEFLON to separate from the metal surface.

Adjusting the Surface Skim Bleed-Off Quantity

The skim time determines the quantity of water skimmed with each fill cycle. The skim time is field adjustable using the VAPOR-LOGIC₂ keypad.

Model STS®-DI Only

The humidifier should be inspected for leaks at least annually. All safety devices in the control cabinet should be cycled on and off to verify that they are functioning.

Cleaning the Evaporating Chamber

As long as mineral-free water is used in the STS-DI humidifier, no cleaning or flushing of the evaporating chamber should be necessary.

STS-DI START-UP AND RECOMMENDED MAINTENANCE

Introduction

After the system has been properly installed and connected to both electrical and water supplies, it may then be started.

Mounting

Check mounting to see that unit is level and securely supported before filling with water.

Piping

Verify that all piping connections have been completed as recommended and that steam and water pressures are available.

Electrical

Verify that all wiring connections have been made in accordance with the STS® wiring diagram.

Control System

For VAPOR-LOGIC₂® microprocessor control system, refer to the *Installation and Operations Manual* enclosed with the product shipment.

Control Circuits

- a) Adjust humidistat to “call” setting.
- b) Open shut-off valve on water supply line. Water should flow through float valve.
- c) Turn electric power on to control cabinet.
- d) Fill the water seal in drain line by manually opening drain valve for a few seconds.
- e) Open steam stop valve. Steam should be heard passing through the automatic steam valve into the humidifier heat exchanger.
- f) Check out function of field installed air flow switch, high limit duct humidistat, and controlling humidistat to ensure that they are in control of steam valve.

Recommended Maintenance-STS-DI System (deionized water)

The STS-DI humidifier does not require regular maintenance. A periodic visual inspection is recommended to identify gasket or piping leaks. Control circuit and safety switches should be checked to verify they properly control the steam valve.

Caution: Overtightening cover will cause leaks.

All cover knobs are turned down at the factory until the bottom of the knob makes contact with the flange, then one half turn further. If more compression is required, turn all knobs a half turn more. Do not turn knobs more than a half turn before identifying that a leak still exists.

TROUBLE SHOOTING GUIDE

Symptom	Possible Cause	Recommended Action
Humidifier Will Not Heat	<p>No control transformer output. Humidistat is not calling.</p> <p>Safety controls open (high limit, air proving, etc...)</p> <p>Faulty control board.</p> <p>Probe corrosion. Steam stop valve closed. Steam trap plugged. Low or no steam. Steam strainer plugged.</p>	<p>Verify control voltage. Set humidistat to "call". Inspect for faulty humidistat.</p> <p>Check safety controls.</p> <p>Verify control voltage and probe. Wires are connected correctly.</p> <p>Replace probes*. Verify valve is opened. Clean trap body. Verify steam is present. Clean strainer.</p>
Humidifier Will Not Fill	<p>No water pressure.</p> <p>Faulty water fill valve.</p> <p>Plugged water strainer. Plugged valve. Faulty control board.</p>	<p>Verify manual water supply valve is open.</p> <p>Verify action of fill solenoid valve, verify control voltage present at coil. Audible click should be heard as solenoid operates.</p> <p>Open strainer. Clean valve. Verify control voltage.</p>
Humidifier Does Not Stop Filling	<p>Lack of tank-to-probes continuity. Water conductivity less than 100 micromhos/cm minimum (2 grains per gallon)</p> <p>Manual drain is not fully closed.</p> <p>Fill valve is stuck open.</p> <p>Fill valve installed backwards.</p>	<p>Jumper terminals 1 & 3 if water sops, verify tank ground to term 3; check water supply conductivity; then consult factory.</p> <p>Close manual ball valve.</p> <p>Check valve for foreign matter.</p> <p>Check for correct water flow, through valve, note arrow.</p>
Low Output	<p>Automatic drain valve not seating.</p> <p>Manual drain is not fully closed.</p> <p>Excessive skimming amount.</p> <p>Fill valve is stuck open.</p> <p>Low supply steam pressure.</p> <p>Steam valve inoperable.</p> <p>Steam trap blocked.</p> <p>Scale coated heat exchanger.</p>	<p>Clean ball and seat of valve.</p> <p>Close manual ball valve.</p> <p>Reduce skimmer or skim time.</p> <p>Check valve for foreign matter.</p> <p>Check steam supply pressure.</p> <p>Not opening fully.</p> <p>Not passing condensate.</p> <p>Clean heat exchanger.</p>
Makeup Water Valve Short Circuits	<p>Electrode probes may be incorrectly wired.</p> <p>Probes are scale coated.</p>	<p>Confirm that wiring agrees with diagram.</p> <p>Clean probes.</p>

*Although the three stainless steel electrode probes will eventually erode due to corrosion they are usually functional for up to approximately 5000 hours of operation.

REPLACEMENT PARTS

Figure 21-1: STS® Humidifier

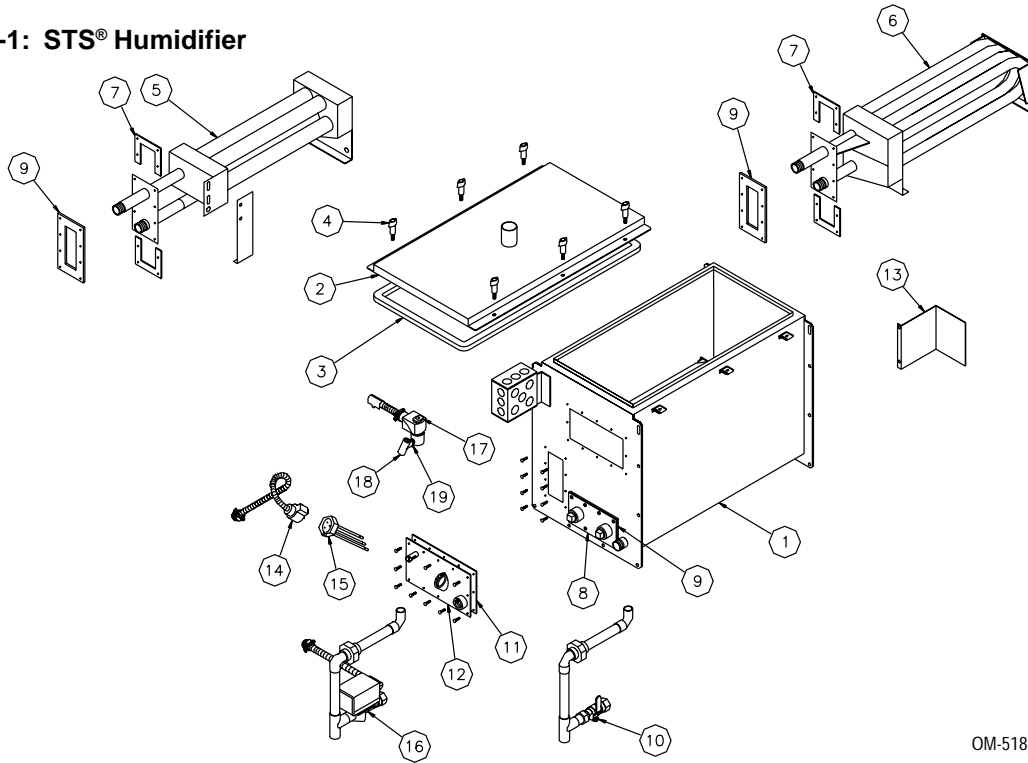

OM-518

Table 21-1: STS Humidifier

No.	Description	Part No.
1	Tank, STS-25	164404-025 *
1	Tank, STS-50	164404-050 *
1	Tank, STS-100	164404-100 *
1	Tank, STS-200/400	164404-400 *
1	Tank, STS 800	164404-800 *
2	Cover, STS-25	165359 *
2	Cover, STS-50	165360 *
2	Cover, STS-100	165365 *
2	Cover, STS-200/400/800	165369 *
3	Gasket, Cover, STS-25	160690-224 *
3	Gasket, Cover, STS-50	160690-240 *
3	Gasket, Cover, STS-100	160690-340 *
3	Gasket, Cover, STS 200/400/800	160690-200 *
4	Knob, T-Handled Utility	700725
5	Heat Exchanger, STS-25S	164420-101 *
5	Heat Exchanger, STS-50S	164420-102 *
5	Heat Exchanger, STS-100S	164420-103 *
5	Heat Exchanger, STS-200S	164420-104 *

* Specify humidifier model and serial numbers when ordering.

Table 21-1: continued

No.	Description	Part No.
6	Heat Exchanger, STS-25C	164436-101 *
6	Heat Exchanger, STS-50C	164436-102 *
6	Heat Exchanger, STS-100C	164436-103 *
6	Heat Exchanger, STS-400/800C	164436-104 *
7	Support, Heat Exchanger Mtg Plate	124437
8	Clean Out Plate	165470
9	Gasket, Clean Out and Mtg Plate	308220
10	Valve, ¾" Ball (Manual Drain)	505011
11	Gasket, Probe/Float Plate	308220-001
12	Probe Plate, STS-25/50/100	164411
12	Probe Plate, STS-200/400/800	164411-002
13	Baffle, Probe Plate	124443
14	Probe Plug	406050-002
15	Probe Assembly	406060
16	Valve, ¾" Electric (Auto Drain)	505400-001
17	Fill Valve, ¼" Solenoid, .125, STS-25, 50, 100	505084
17	Fill Valve, ¼" Solenoid, .281, STS-400, 800	505085
18	Strainer, ¼" Sediment	300050
19	Valve, Needle ¼"	505070-001

* Specify humidifier model and serial numbers when ordering.

REPLACEMENT PARTS

Figure 22-1: STS®-DI Humidifier

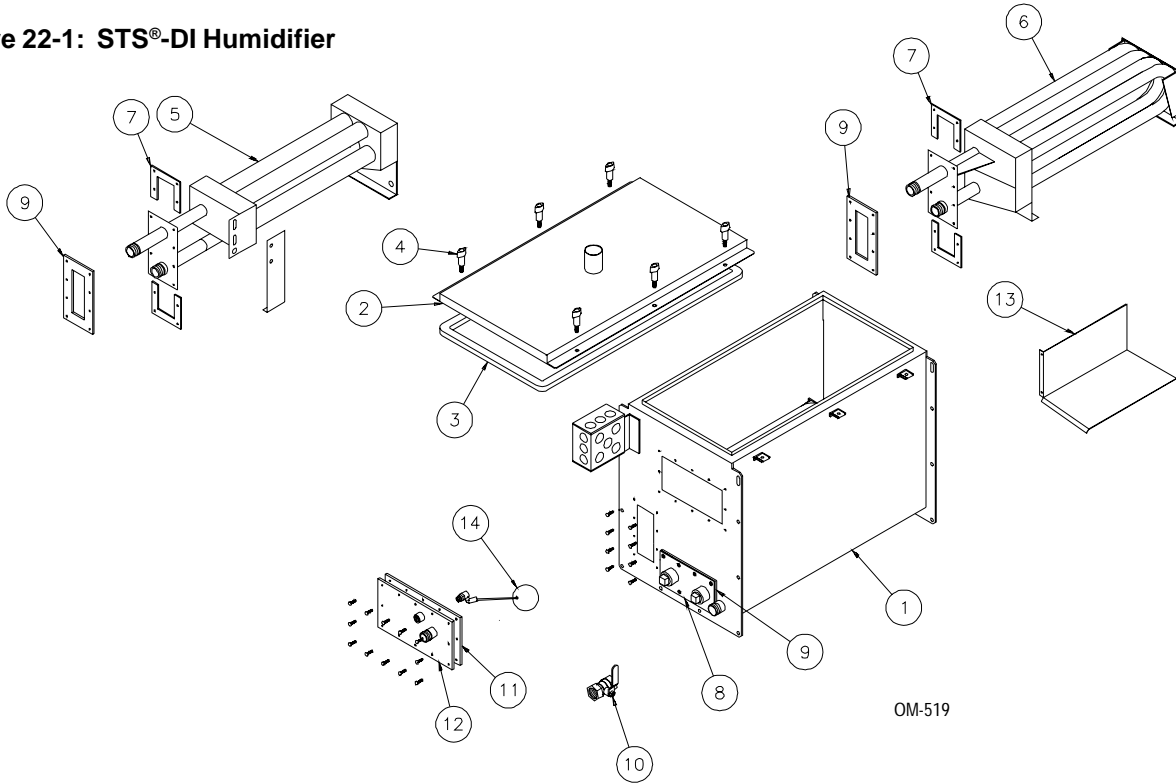

OM-519

Table 22-1: STS-DI Humidifier

No.	Description	Part No.
1	Tank, STS-25	164404-025 *
1	Tank, STS-50	164404-050 *
1	Tank, STS-100	164404-100 *
1	Tank, STS-200/400	164404-400 *
1	Tank, STS 800	164404-800 *
2	Cover, STS-25	165359 *
2	Cover, STS-50	165360 *
2	Cover, STS-100	165365 *
2	Cover, STS-200/400/800	165369 *
3	Gasket, Cover, STS-25	160690-224 *
3	Gasket, Cover, STS-50	160690-240 *
3	Gasket, Cover, STS-100	160690-340 *
3	Gasket, Cover, STS 200/400/800	160690-200 *
4	Knob, T-Handled Utility	700725
5	Heat Exchanger, STS-25S	164420-101 *
5	Heat Exchanger, STS-50S	164420-102 *
5	Heat Exchanger, STS-100S	164420-103 *
5	Heat Exchanger, STS-200S	164420-104 *

Table 22-1: continued

No.	Description	Part No.
6	Heat Exchanger, STS-25C	164436-101 *
6	Heat Exchanger, STS-50C	164436-102 *
6	Heat Exchanger, STS-100C	164436-103 *
6	Heat Exchanger, STS-400/800C	164436-104 *
7	Support, Heat Exchanger Mtg Plate	124437
8	Clean Out Plate	165470
9	Gasket, Clean Out and Mtg Plate	308220
10	Valve, 3/4" Ball (Manual Drain)	505011
11	Gasket, Probe/Float Plate	308220-001
12	Float Plate, STS-25/50/100	164410
12	Float Plate, STS-200/400/800	164410-002
13	Baffle, Probe Plate	124442
14	Float Valve Assembly STS 25-400	505210
14	Float Valve Assembly STS 25-800	505300

* Specify humidifier model and serial numbers when ordering.

* Specify humidifier model and serial numbers when ordering.

REPLACEMENT PARTS

Figure 23-1: STS® Control Cabinet with VAPOR-LOGIC®₂ Controls

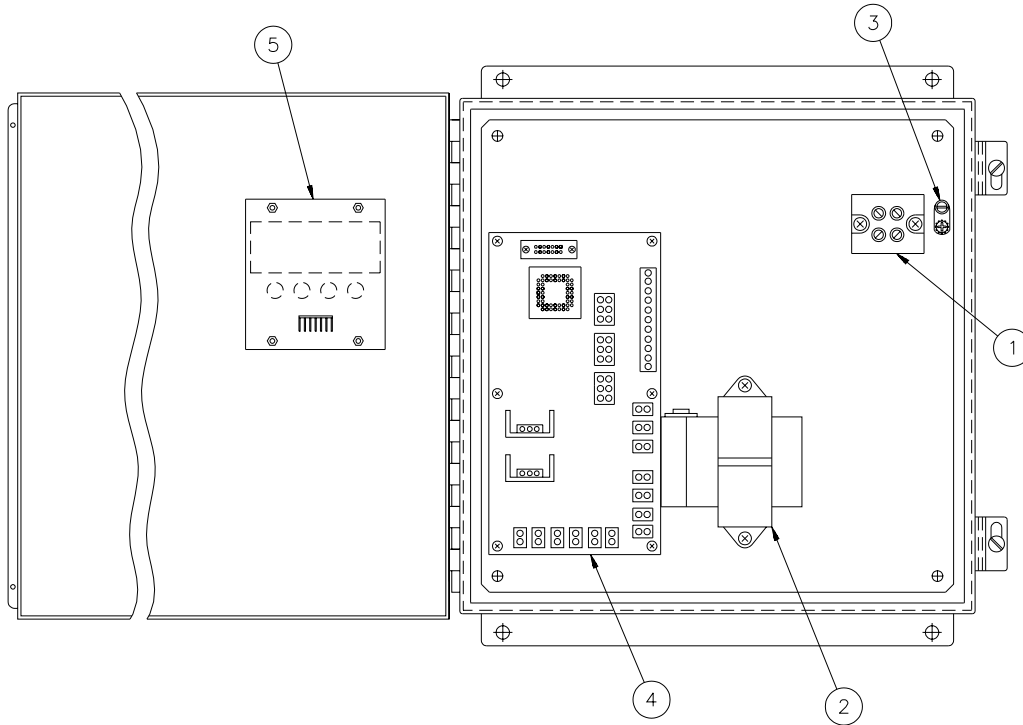

OM-1044

Table 23-1: VAPOR-LOGIC®₂ Controls

No.	Description	Part No.
1	Power Block	408300-001
2	Transformer	408960
3	Ground Lug	409250-017
4	LW430, Microprocessor Board	408641
5	LW440, Display Board	408651

TWO-YEAR LIMITED WARRANTY

DRI-STEEM Humidifier Company ("DRI-STEEM") warrants to the original user that its products will be free from defects in materials and workmanship for a period of two (2) years after installation or twenty-seven (27) months from the date DRI-STEEM ships such product, whichever date is the earlier.

If any DRI-STEEM product is found to be defective in material or workmanship during the applicable warranty period, DRI-STEEM's entire liability, and the purchaser's sole and exclusive remedy, shall be the repair or replacement of the defective product, or the refund of the purchase price, at DRI-STEEM's election. DRI-STEEM shall not be liable for any costs or expenses, whether direct or indirect, associated with the installation, removal or re-installation of any defective product.

DRI-STEEM's limited warranty shall not be effective or actionable unless there is compliance with all installation and operating instructions furnished by DRI-STEEM, or if the products have been modified or altered without the written consent of DRI-STEEM, or if such products have been subject to accident, misuse, mishandling, tampering, negligence or improper maintenance. Any warranty claim must be submitted to DRI-STEEM in writing within the stated warranty period.

DRI-STEEM's limited warranty is made in lieu of, and DRI-STEEM disclaims all other warranties, whether express or implied, including but not limited to any IMPLIED WARRANTY OF MERCHANTABILITY, ANY IMPLIED WARRANTY OF FITNESS FOR A PARTICULAR PURPOSE, any implied warranty arising out of a course of dealing or of performance, custom or usage of trade.

DRI-STEEM SHALL NOT, UNDER ANY CIRCUMSTANCES BE LIABLE FOR ANY DIRECT, INDIRECT, INCIDENTAL, SPECIAL OR CONSEQUENTIAL DAMAGES (INCLUDING, BUT NOT LIMITED TO, LOSS OF PROFITS, REVENUE OR BUSINESS) OR DAMAGE OR INJURY TO PERSONS OR PROPERTY IN ANY WAY RELATED TO THE MANUFACTURE OR THE USE OF ITS PRODUCTS. The exclusion applies regardless of whether such damages are sought based on breach of warranty, breach of contract, negligence, strict liability in tort, or any other legal theory, even if DRI-STEEM has notice of the possibility of such damages.

By purchasing DRI-STEEM's products, the purchaser agrees to the terms and conditions of this limited warranty.

DRI-STEEM[®]
HUMIDIFIER COMPANY



14949 Technology Drive • Eden Prairie, MN 55344
Phone: (952) 949-2415 • Fax: (952) 949-2933
E-Mail: sales@dristeem.com • Web: www.dristeem.com

International Office:

Bell Place, Bell Lane • Syresham, Brackley • NN13 5HP, U.K.
Phone: +44 1280 850122
Fax: +44 1280 850124
E-Mail: 106277.1443@compuserve.com

Continuous product improvement is a policy of DRI-STEEM Humidifier Company therefore, product features and specifications are subject to change without notice.

DRI-STEEM, RAPID-SORB, STS, VAPOR-LOGIC and VAPOR-LOGIC, are Registered Trademarks of the DRI-STEEM Humidifier Company.
TEFLON is a Registered Trademark of Dupont.