



# Herrtronic AD Series

Electronic Steam Humidifiers

**Installation  
Operation  
Service**

## **OWNER'S MANUAL**

The AD Series Humidifiers represent the latest in humidification technology. Please read these instructions carefully for trouble free operation and to get the most out of your purchase. For further information concerning this product, contact your local Herrmidifier representative.



# TABLE OF CONTENTS

## SECTION I WARRANTY

Warranty.....	Page 3
---------------	-----------

## SECTION II UNIT OPERATION

Basic Operation .....	4
Key Features.....	5
Engineering and Application.....	6

## SECTION III INSTALLATION INSTRUCTIONS

Mounting.....	7
Plumbing.....	7
Supply Power.....	8
Steam Distribution.....	8-9
Control Circuit Connections.....	10

## SECTION IV OPERATING INSTRUCTIONS

Start-Up Instructions.....	11
Check List .....	12
Maintenance.....	13

## SECTION V TROUBLESHOOTING GUIDE

Trouble Shooting Unit Detected Faults.....	14
Trouble Shooting Non-Fault Activated Problems.....	15-16
Circuit Board Diagram .....	17
Exploded View and Part Lists.....	18-22
Unit Wiring Diagram.....	23

## **SECTION I WARRANTY**

1. TRION, Inc. warrants to the buyer or any user during the duration of the Warranty that the humidifier described in this manual will be free from defects of material and workmanship for a period of two (2) years from the date of shipment.
2. For this Warranty to be effective, this humidifier must be installed, operated and maintained in accordance with the Installation Instructions, Operations and Service Manual(s) supplied with the humidifier.
3. In the event of a defect or malfunction in this product during the Warranty Period, user may return the humidifier to the Herrmidifier Factory Repair Department for complete reconditioning without charge to the user for parts or labor. Incidental expenses such as costs of transporting the humidifier to the Factory Repair Department shall be borne by the user. Upon completion of the reconditioning, the humidifier will be returned F.O.B. Destination (in the continental USA) at no cost to the user.
4. Each of the Herrtronic series of steam generating humidifiers contains a plastic steam generating cylinder which is to be considered a routinely disposable part to be changed at regular maintenance intervals at the user's expense. This steam generating cylinder is not covered by this Warranty. If, after the first installation of your Herrtronic humidifier, you feel the steam generating cylinder is not operating normally, you should return the cylinder to Trion, Inc. with an explanation of the problem. However, in the continuing operation of this humidifier, replacements of this part are your responsibility as part of routine maintenance.

5. **This Warranty does not cover field labor for repairs to this humidifier or any special, indirect or consequential damages.** Some states do not allow the exclusion or limitation of incidental or consequential damages, so the above limitation may not apply to you.
6. If, after a reasonable number of attempts to do so, the TRION, Inc. is unable to remedy any defects or malfunctions in this humidifier, then the user may elect either a replacement of such product or part which may be defective without charge or a refund at the buyer's original purchase price.
7. This Warranty gives you specific legal rights, and you may also have other rights which vary from state to state.

## SECTION II UNIT OPERATION

### Basic Operation

Controlled humidification requires a very precise control system. The Herrtronic AD utilizes a solid state control to monitor performance and maintain humidity. Further, the Herrtronic AD evaluates the operation and alerts the operator to problem conditions and prevents undesirable operation.

**1. Start-up:** On initial start-up (prompted by the humidistat), the fill valve opens allowing water to enter the cylinder. When the water level rises to the electrodes, current will flow and the water will begin heating. As the water temperature rises, its conductivity also increases, accelerating the rate of temperature increase. When the output reaches the "capacity set point", the fill valve closes. The output capacity may continue to rise slightly beyond the "capacity set point". As the water boils, the water level falls with resulting output reduction.

**2. Normal Operation:** Upon achieving "capacity set point", the system begins operation in a steady state mode. Output capacity slowly decreases until the elapsed "cycle time" opens the fill valve to replenish the

water level until the "capacity set point" output is achieved. As the mineral concentration in the water increases, the water conductivity also increases. Accordingly, the rate of boiling increases. Eventually, the rate of boiling reduces the output capacity below the "low drain threshold" before the "cycle time" initiates the fill cycle. At this point, the drain valve opens discarding the mineral laden (highly conductive) water, replacing with fresh water, that lowers the mineral concentration until the system is restored to the steady state mode.

This steady state operating mode continues with small increases in the water level to maintain output capacity (exposing new electrode surface).

**3. End-of-Cylinder Life:** Steady state operation continues with "fill and boil" and periodic drain cycles with ever increasing water levels. Eventually, the water level reaches the cylinder full electrode, representing the maximum allowable water level. The system output begins to decrease since there is no new electrode surface to expose. If the system operates 45 minutes continuously without achieving "capacity set point", the fault light will illuminate indicating an "end of cylinder life fault." Cylinder replacement should occur to maintain satisfactory humidity levels.

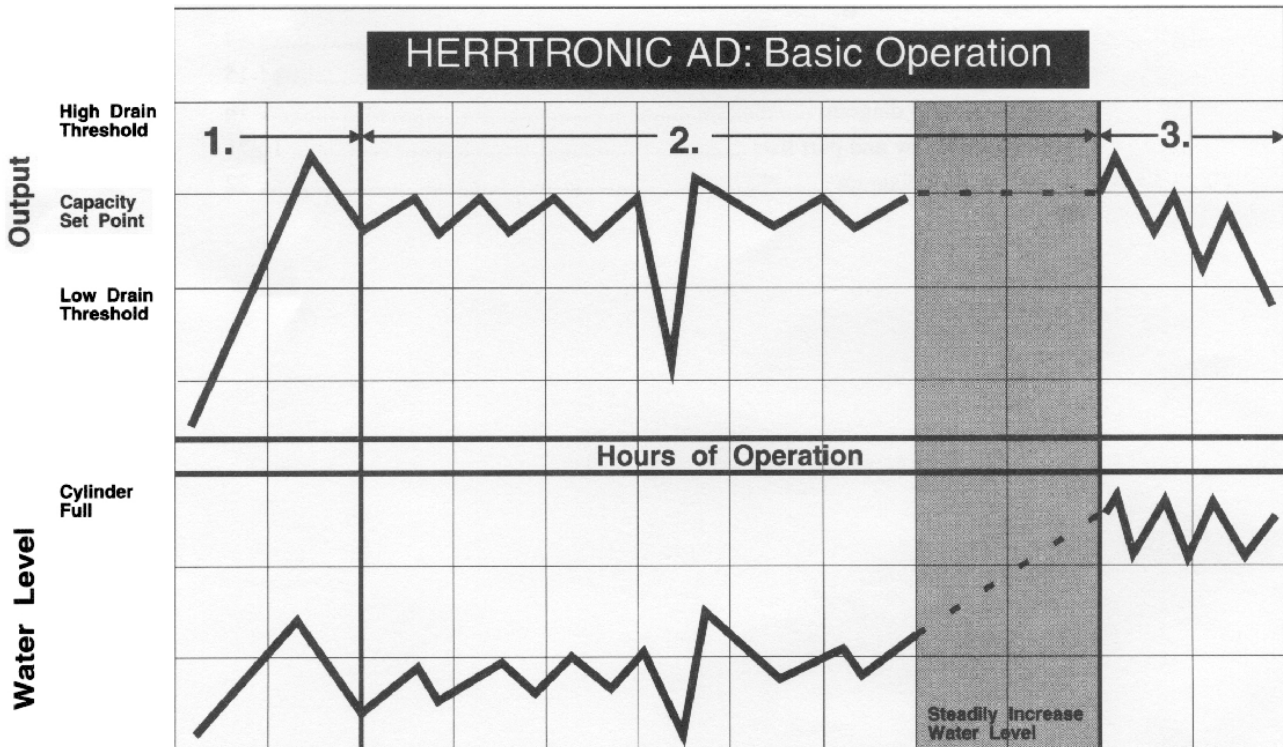

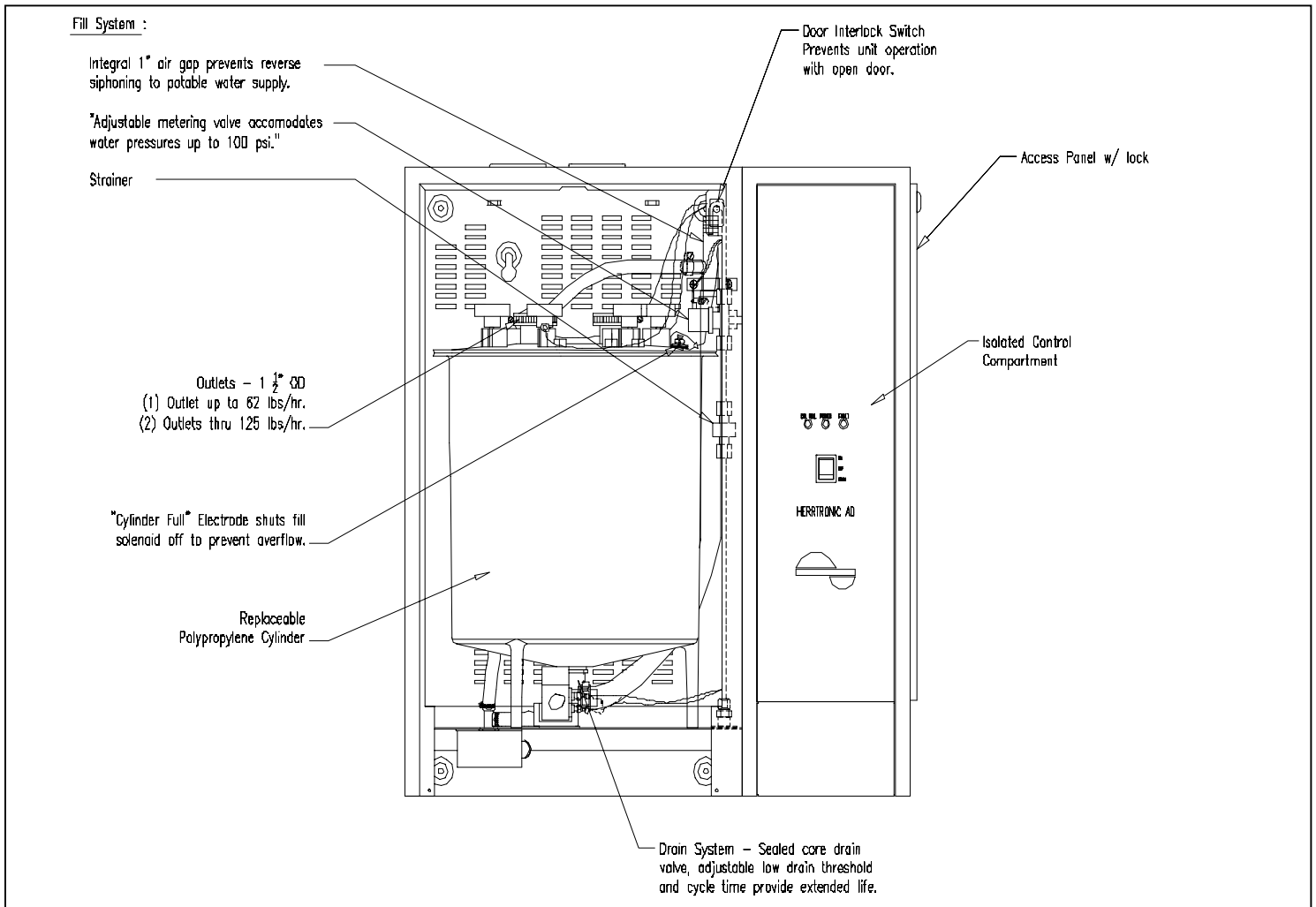

Conductivity* Micromhos (approx.)	Average Life** Expectancy - Hrs. (approx.)
70	2000
100	2000
135	1900
170	1800
255	1300
510	800
765	650
1020	500

*\*If the conductivity of your supply water is less than 100 micromho, Consult Hermidifier for specific circuit board adjustments.  
\*\*Your actual cylinder life may be higher or lower depending on the exact composition of your water supply.*

### Adjustable Set-point

#### Capacity

- Range=50-100%
- Preset at 100%

#### Low Drain Threshold

- Range=50-100%
- Preset; setting varies by unit

#### Cycle Time

- Range=60-300 Sec.
- Preset; setting varies by unit

### Faults

#### Overcurrent

- 120% of Rated Current
- System Shutdown

#### Cylinder Fill

- Fill valve open for 45 minutes without achieving capacity setpoint
- System Shutdown

#### End of Cylinder Life

- 45 Minutes of operation without achieving capacity setpoint
- System Shutdown

**Engineering and Application**

Herrtronic AD Series Steam Humidifiers can be applied in a variety of applications. The simplest application consists of an "AD" unit and an "RDU" (Room Distribution Unit). Steam is generated by the "AD" unit, transferred to the "RDU" unit, and distributed into the conditioned space. As shown in Figure 1, the "RDU" unit can be mounted on the "AD" unit or remote from the "AD" unit. Steam input is either into the bottom or rear of the "RDU" unit. In this application, only the "RDU" unit need be in the conditioned space. One "RDU" unit is

**NOTE**

A separate condensate return line must be installed during installation.

required for up to 125 lbs./hr. of humidification. Alternatively, steam generated by an "AD" unit can be discharged directly into the system ductwork. In this application, steam distributor pipe(s) are preferably installed in the system ductwork at least three (3) feet down steam of the supply air blower. There should be no obstructions within the first three feet down steam of the humidifier as shown in Figure 2. If the blower operates intermittently ("Auto"), an air-proving switch should be

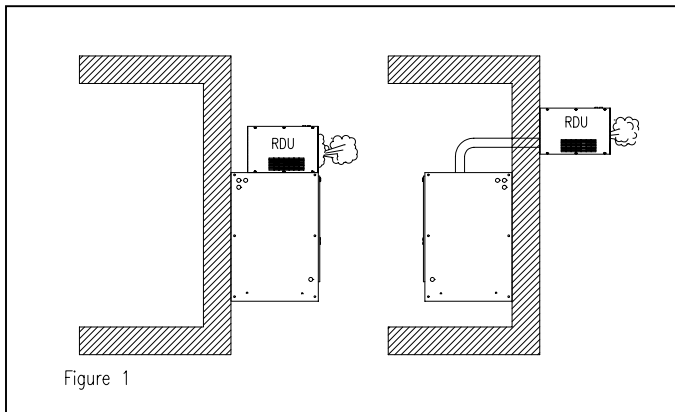

operation. Further, a high limit humidistat (located ten feet downstream of the humidifier steam distributor) should be included for better system control.

The number of steam distributor pipes will be at least equal to the number of steam outlets on the humidifier - i.e., ADM & ADS (up to 65 lbs./hr.) =1, ADS (65 - 125 lbs./hr.) =2. A "Y" connector (EST - 255) is available to convert one steam outlet into two steam distributor inputs. Figures 5, 6, and 7 reflect the spacing required within the duct.

**NOTE**

The steam distributor pipes are inherently sloped to return the condensate to the humidifier.

The steam piping from the humidifier to the steam distributor should have an 8% slope up to the steam distributor. Steam hose may be used up to a maximum of 20 feet between the unit and the steam distributor. Beyond 20 feet, system capacity is reduced unless insulated copper pipe (1 1/2" ID) is used. If there are any low spots between the humidifier and the steam distributor, a condensate separator (EST-250) should be used (Figure 8).

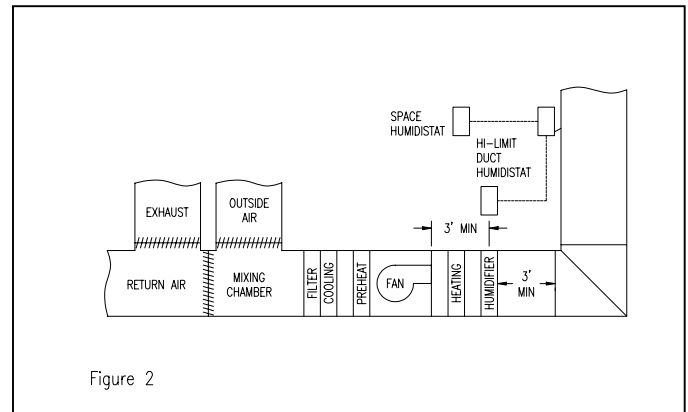

provided to assure blower operation prior to humidifier

## SECTION III INSTALLATION INSTRUCTIONS

### Mounting

The cabinet is designed to safely contain the working parts of the Herrtronic AD Series and dissipate heat to protect the electronics. Herrtronic AD Series electronic steam humidifiers, room distribution unit, steam pipes, and any accessories should be located in a manner to facilitate routine inspection and any necessary maintenance. **The unit should not be located above (such as false ceilings) or around valuable property where an equipment malfunction could cause damage.** Correct positioning of the Herrtronic AD Series is important to allow for proper operation and easy maintenance. Minimum clearances around the cabinet should be maintained as shown:

UNIT SERIES	CLEARANCES	
	ADM 5-30#	ADS 10-100#
Left	2"	2"
Right	15"	15"
Top	12"	12"
Bottom	10"	10"

### Allowable Operating Conditions

Ambient Temperature: 40°F (4°C) to 120°F (50°C)

Ambient Relative Humidity: 0% to 90% (non-condensing)

Line Voltage: -15% to +10% of Nominal

Frequency: 50/60 HZ.

Supply Water Pressure: 20 psi- 1 00 psi

Supply Water Temperature: 40°F- 1 00°F

Supply Water Conductivity: 70- 1 000 micromho

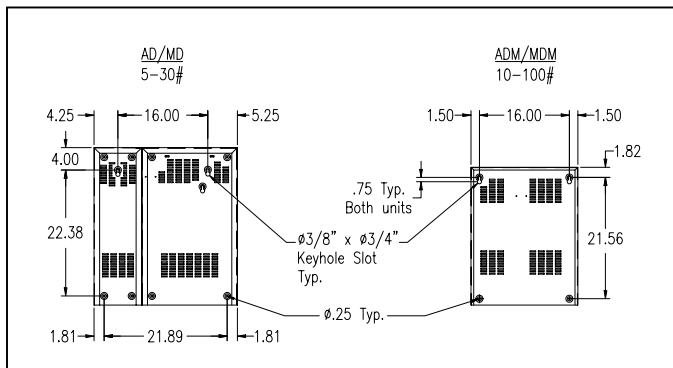

Four lag bolts, (2) 5/16" and (2) 1/4", are supplied with the AD Series which is designed to be secured to a wall. Install the top two lag bolts (5/16") according to the dimensions in Figure 3. Hang the unit on the wall, and then install the bottom two lag bolts (1/4") and secure all four bolts. Be sure the unit is mounted directly to the wall - to wood studs at least 2" thick (or equivalent).

### NOTE

To mount the Room Distribution Unit refer to the supplemental RDU Installation Instructions.

### WARNING!

**Do not** mount any controls inside the unit or tap power from any location in the unit, except as stated in these instructions. **Do not** place objects near the cabinet. **Do not** attach to dry wall without studs.

### Plumbing

To make the necessary connections for water fill, cylinder drain and cabinet drain, the following steps are required: (refer to Figure 3 for locations)

1. Install an external shutoff valve between the water supply and the humidifier for ease in servicing of the unit.
2. Connect water supply to 1/2" compression fitting on the bottom of the cabinet using copper, PVC, or plastic tubing.
3. A 3/4" hose barb adapter extends from the side of the drain reservoir on the bottom of the unit. This reservoir collects both the cylinder and the cabinet drains in one location. A 3/4" I.D. vinyl tube is included to be connected to the drain reservoir and the drain line. The drain line must be a minimum 1" I.D. PVC or copper line.

### NOTE

Inlet water pressure must be in the range of 20-100 psig. Consult the factory if you are outside of this range. Softened water may be used and requires that the low drain threshold be "adjusted."

### WARNING!

**Do not** mount any controls inside the unit or tap power from any location in the unit, except as stated in these instructions. **Do not** place objects near the cabinet. **Do not** attach to dry wall without studs.

### WARNING!

**Do not** use plastic drain line unless "Drain Tempering" is enabled. See page 11 for drain tempering instructions.

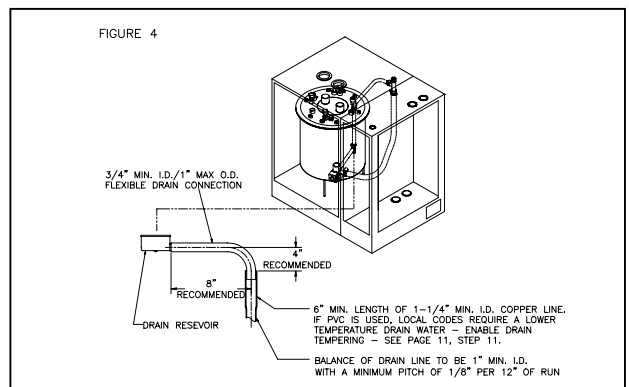

**Supply Power**

1. Insure that adequate service is available to carry 125% of rated amps level. (refer to chart below).  
 2. Terminals are provided in the lower right hand corner of the electrical compartment for field connection of the main power supply legs (single or three phase) and a ground wire.

3. Install external overcurrent protection and provide wiring in accordance with the NEC, state and local codes.  
 4. Power supply must be "clean": free of spikes, surges and sags: +10%, -15% of nominal.  
 5. Check tightness of all power wiring connection -  
 Factory wiring: 35-45 in-lbs.  
 Field wiring: 35-275 in-lbs.  
 See Power Distribution Blocks for Exact Specification

**Steam Output / Electrical Characteristics**

STEAM OUTPUT												
Lbs./Hr.	5	10	15	20	25	30	40	50	60	80	100	125
Kg./Hr.	2.3	4.5	6.8	9.1	11.4	13.6	18.2	22.7	27.2	36.3	45.4	56.8
INPUT KW												
	1.7	3.3	5.0	6.6	8.3	10.0	13.3	16.7	20.0	26.6	33.3	41.2
Volts/Ph:	AMPS											
208/1	8.0	16.0	24.0	32.0	40.0	48.1	64.1	80.1				
240/1	6.9	13.8	20.8	27.6	34.7	41.7	55.6	69.4				
208/3	4.6	9.2	13.9	18.5	23.1	27.8	37.0	46.3	55.5	74.0	92.6	115.7
240/3	4.0	8.0	12.0	16.0	20.0	24.1	32.1	40.1	48.1	64.2	80.2	100.2
480/3	2.0	4.0	6.0	8.0	10.0	12.0	16.0	20.0	24.0	32.1	40.1	50.1
600/3	1.6	3.2	4.8	6.4	8.0	9.6	12.8	16.0	19.2	25.6	32.1	40.1

- Kg/Hr = .454 x lbs./hr.
- Kw = .33 x lbs./hr.
- Amps (1Ph) = Kw x 1000 ÷ Volt.
- Amps (3Ph) = Kw x 1000 ÷ (Volts x 1.732)
- Min Circuit Ampacity = 1.25 Rated Electrode Amps (for each RDU, add .5 Amps @ 208/240v or add .25 Amps @ 480v).

**Distribution Method**

Each steam cylinder requires at least one outlet for steam via a duct distributor pipe or Room Distribution Unit.

**Steam Distributor Pipes**

Herrmidifier supplies stainless steel duct distributor pipe(s) for use in injecting pure steam into duct. Refer to Figures 5, 6 or 7 for proper placement. A minimum of 3' downstream clearance before any bends or obstructions is recommended for most applications, however differing psychrometric conditions may require a greater or lesser steam absorption distance. Consult your representative or the factory if you have any questions. The duct distributor pipes have a built-in pitch to allow condensate drainage back into the hose. **The rubber steam hose is of large diameter and is meant to carry steam up to the distributor pipe and condensate back to the steam cylinder for reuse.** Because of this dual purpose of the steam hose, it must be installed with a minimum 8% pitch back to the Herrtronic AD unit. Since steam output losses are directly related to the distance from the humidifier to the steam distributor, it is recommended:

- a. Mount the humidifier as close as possible to the steam distribution pipe.
- b. Use 1 1/2" I.D. insulated copper pipe if the length of run exceeds twenty feet.
- c. Keep the total run of copper pipe under thirty feet since the actual capacity of the humidifier can be reduced by up to 15% and the increased static pressure may cause problems with the fill tee.

If possible, mount the steam distributor pipe to avoid low spots in the steam hose. If you must, mount the steam distributor pipe below the level of the humidifier, or if low spots in the steam line are unavoidable, a condensate separator is available from the factory (Part #EST-250) (see Figure 8).

If it is necessary to split the output of one steam outlet into more than one steam pipe, steam hose "Y" connector assemblies are available from the factory (Part #EST- 255). In this case, both ducts must be the same static pressure for proper distribution.

**NOTE**

Steam holes are located within 2" of mounting plate and closed end of distribution pipe. Use extreme caution when applying to internally lined duct. Consult factory if special hole locations are required.

**WARNING!**

Do not mount the standard steam distribution pipe in a vertical downflow duct. The combination of static pressure and velocity pressure may be more than the cylinder and/or the fill tee can handle. A special steam distributor must be ordered when installing in a vertical downflow duct

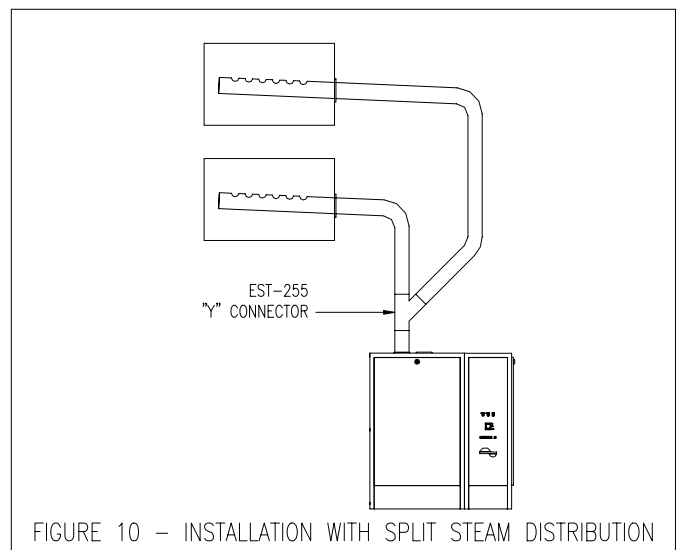
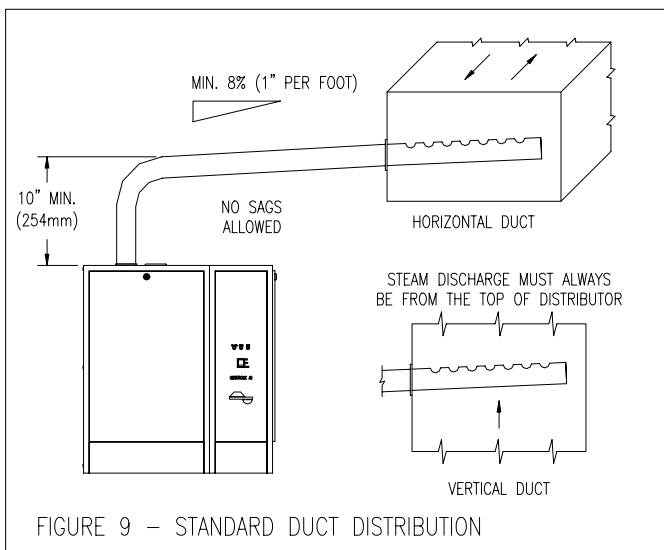
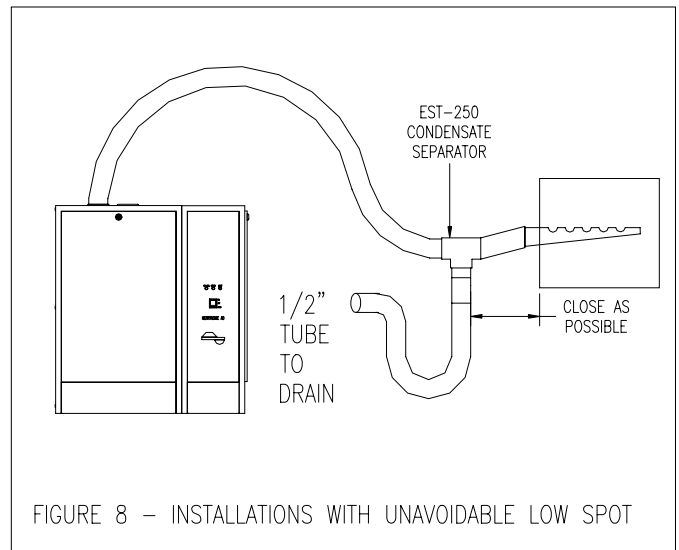
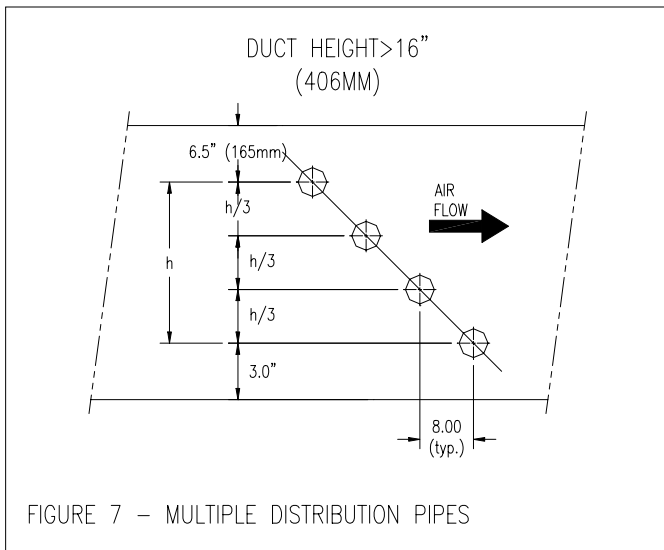
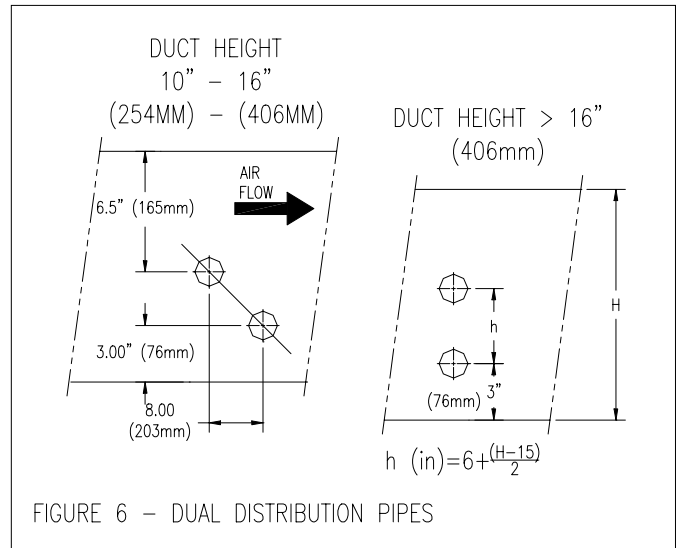
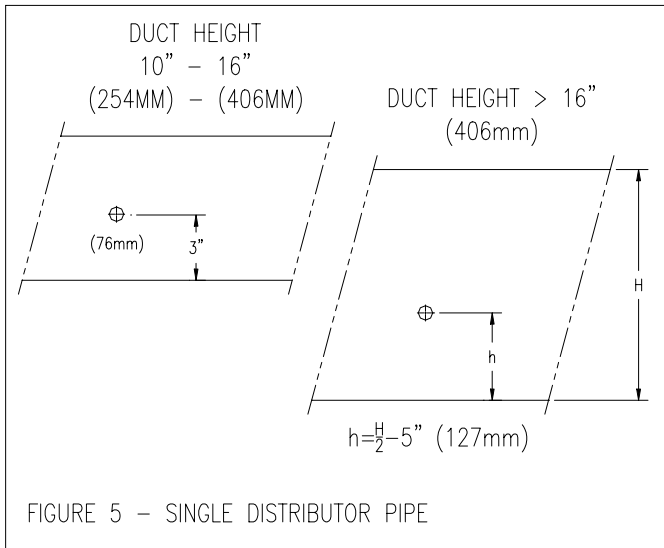

## Wiring

All field wiring should be routed up through the bottom panel (refer to Figure 11 for locations).

A	Drain Connection – 3/4" Hose. Use 3/4" flexible tube included to connect drain reservoir to 1" Min. drain line.
B	Knockout for Control Wiring
C	Fill Connection – 1/2" Compression
D	Knockout for Main Power Supply

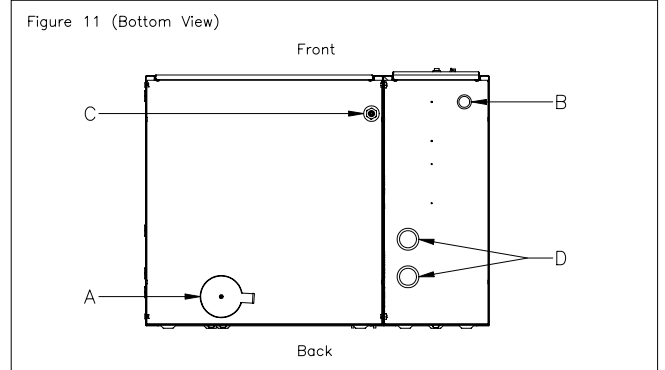

## Control Circuit Connections

### WARNING!

Do not mount the standard steam distribution pipe in a vertical downflow duct. The combination of static pressure and velocity pressure may be more than the cylinder and/or the fill tee can handle. A special steam distributor must be ordered when installing in a vertical downflow duct.

All external electrical control circuits are to be connected to the humidifier using the 12 pole control terminal strip located in the low voltage electrical compartment. The terminal strip is accessed through the front door or the electrical compartment door. A cable tie is provided to secure all control wiring. All control wiring should be 18 AWG or larger.

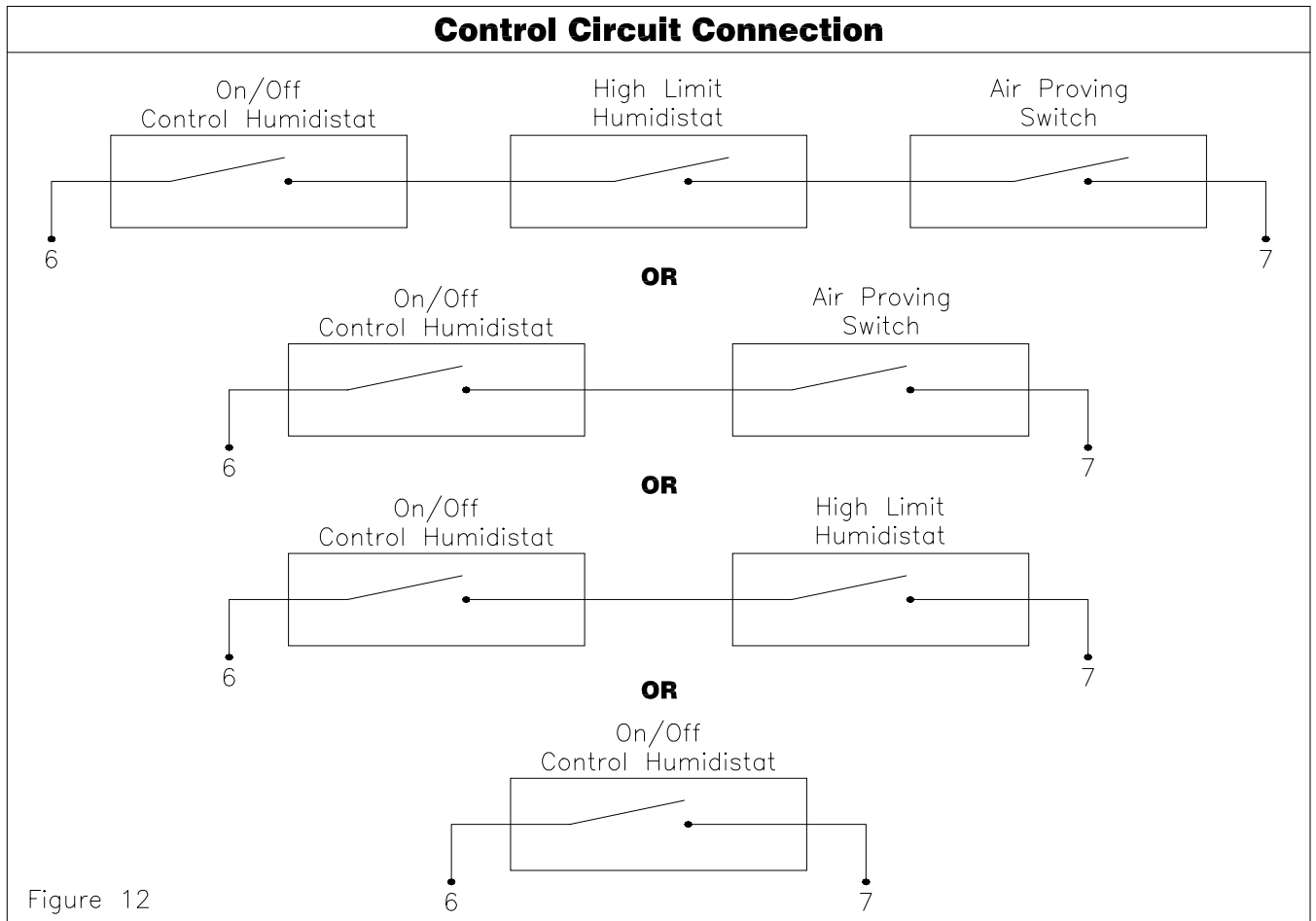

Figure 12

## **SECTION IV OPERATING INSTRUCTIONS**

### **Start-up Instructions**

1. Check that the humidifier is properly mounted and level.
2. Check that the fill water, unit drain, and cabinet drain are properly connected.
3. Check that the correct voltage and amperage services are supplied.
4. Check that the humidifier is specified to match your controls and that all controls are wired properly.
5. Check that the steam distributor or room distribution unit is properly installed and that the steam hose has been properly routed without any kinks or flat spots. Use a condensate separator (Herrmidifier P/N EST-250) for any unavoidable low spots.
6. With power off, double check all electrical connections and plumbing connections to insure that they did not loosen during shipment.
7. With the manual drain switch in the "run" position, and high limit and control humidistats at their lowest setting, turn on the main disconnect. Contactors should remain de-energized but the power lamp should illuminate.
8. Turn the control and high limit humidistats up to their highest setting. The contactor(s) should pull in.
9. After approximately a twenty second delay, the fill solenoid should energize and water begins to fill the humidifier to the preset amp level or cylinder full condition, depending on the incoming water supply. When starting up the unit, it is best to put an amp clamp on the power leg that passes through the torroid transformer. Insure that the humidifier fills to "cylinder full" (approximately 1.5" from the top of the cylinder), or that the amperage reaches the data plate maximum and the fill solenoid turns "off".
10. If after installing jumper wires on ADS unit, or if any ADM unit fails to reach 75% of output, follow instructions in Troubleshooting Section, item K to quickly achieve 100% of output.
11. If plastic drain line is used or local codes require a lower drain water temperature, drain tempering must be enabled. To enable, place the diode supplied in the accessory pack in to the open socket labeled "DR18" on the P.C. board. Be sure the silver band on the diode is properly oriented with the PCB labeling. See page 16 (Figure 23) for the location of CR18. The addition of this diode will energize the fill solenoid whenever the drain solenoid is automatically energized by the control board. The fill solenoid will NOT be energized when using the manual drain switch. Therefore, be sure to allow the water in the tank to sufficiently cool prior to utilizing the manual drain. Some adjustment of the fill solenoid metering valve may be necessary to allow proper drain rate and water temperature.

#### **NOTE**

The capacity of the humidifier can be reduced up to 50% of the factory set maximum level by adjusting the capacity adjustment potentiometer (labeled R39) on the main circuit board.

#### **NOTE**

##### **For ADS UNITS ONLY**

If you have a humidifier that has two power wires (some single phase units) or three power wires (some three phase units), you will find several jumper wires in your accessory pack. On initial start-up, if the unit fills to cylinder full and reaches less than 75% of its rated amp draw, turn off the unit, disconnect the power supply and install the jumper wires between each power electrode and the unused electrode next to it. (See page 13 for proper connection procedure). Restart the humidifier following the above instructions.

# Herrtronic AD Humidifier Checklist

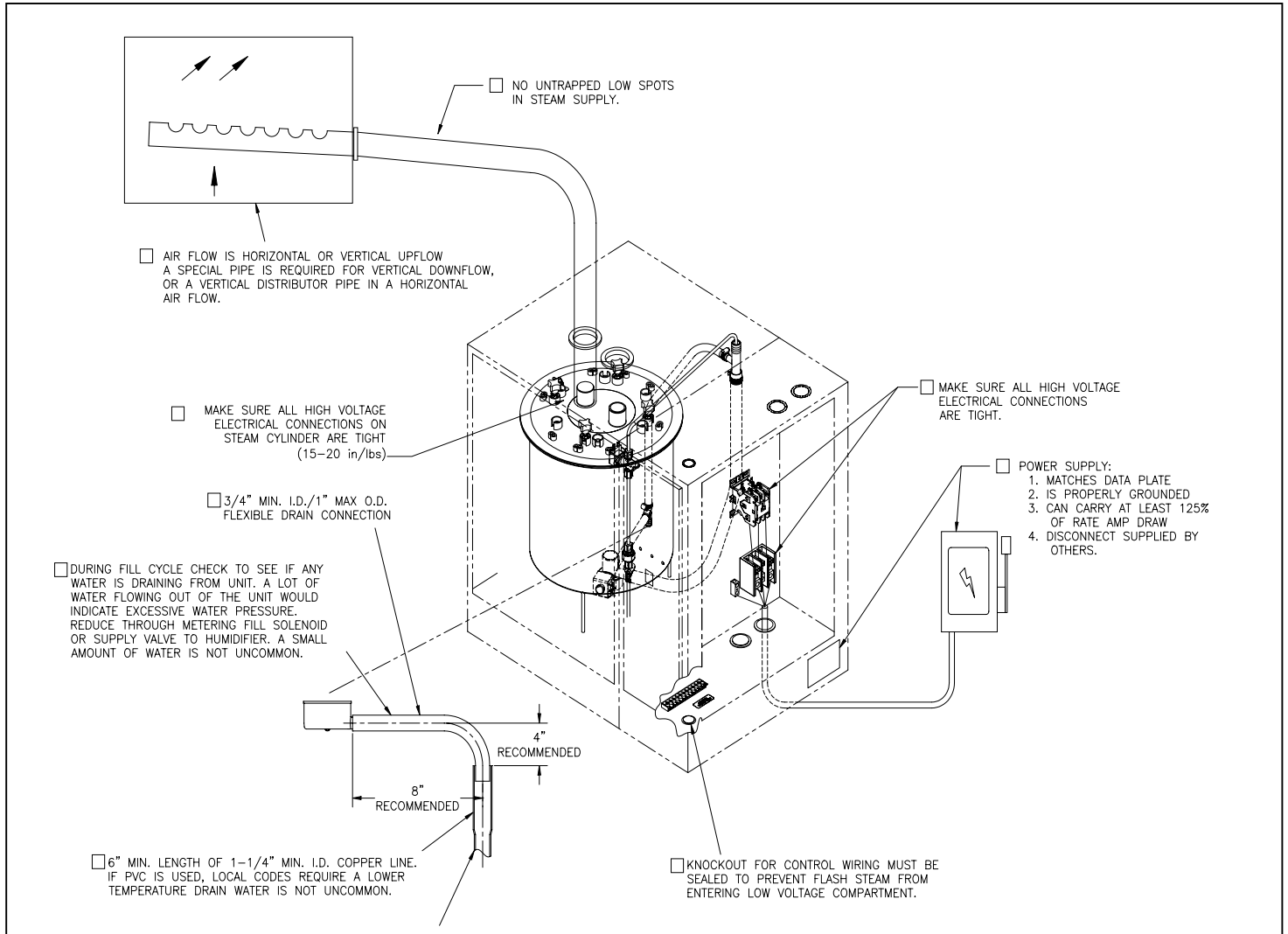

## NOTE

The Herrtronic AD Humidifier checklist is provided to help the installer insure a successful installation. If further assistance is needed from the Herrmidifier representative or the factory, the checklist is expected to be completed. If a jobsite visit is required from the Herrmidifier representative or the factory, and the checklist has not been accurately completed, additional charges will be required by the individual(s) representing Herrmidifier. If the visit uncovers a component malfunction, the parts will be replaced under warranty.

Project Name \_\_\_\_\_

Checklist completed by \_\_\_\_\_

Humidifier Installer (Company) \_\_\_\_\_

Checklist completion date \_\_\_\_\_

## Maintenance

To maintain efficiency, the water level in the cylinder will slowly move upwards, as the electrodes become coated with minerals, to expose new electrode to the water. Eventually all of the usable electrode surfaces will be coated and the cylinder will be full of water. At this point, the “cylinder full” light will turn on and the output will begin to fall. This indicates the need to change the cylinder – typically 500-2000 hours of operation, depending on water supply.

### To remove the cylinder

1. Drain cylinder completely using the Manual Drain Switch.
2. Turn off power to the unit. Disconnect electrode power wires and cylinder full electrode wire from tank.

3. Remove tank and replace with new one. Be sure that both “o” rings are in place on the cylinder fill/drain neck prior to installation. Clean and check both the fill and drain solenoids while servicing the unit. Check strainer. If it is dirty or restricting water flow – replace. Insert new fill valve / strainer.
4. Install cylinder in unit. Make sure that all electrical connections are securely tightened.
5. Follow cold start-up instructions on page 11.

### Extended Shutdown

Always drain cylinder completely if unit will be off for an extended period of time. This will preserve the life of the cylinder.

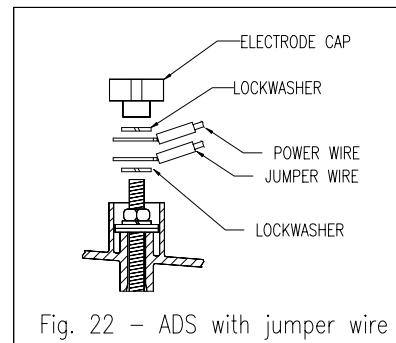
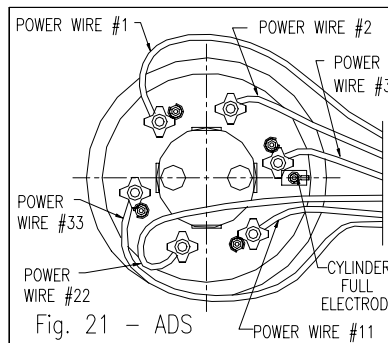
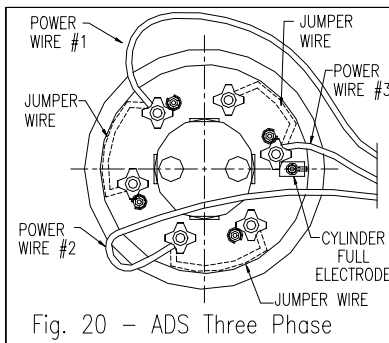
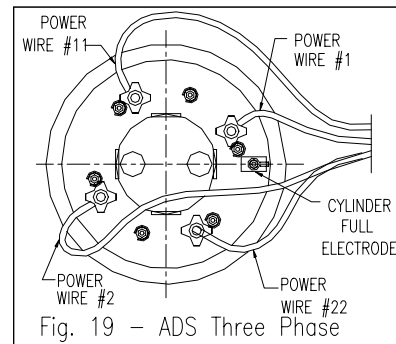
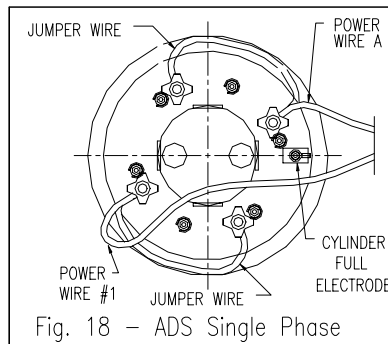
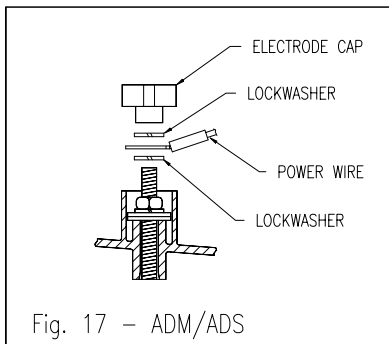
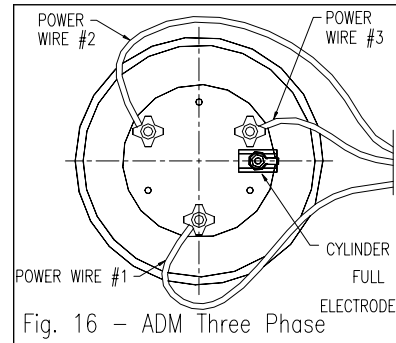
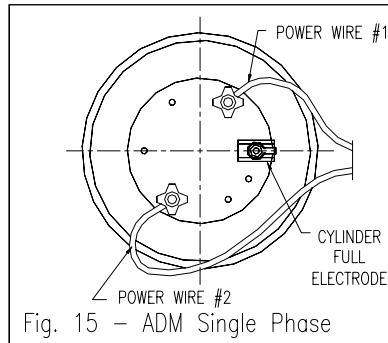
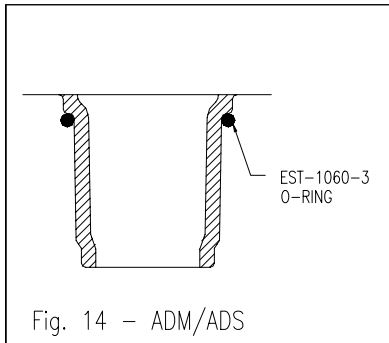

## Section V TROUBLESHOOTING GUIDE

All Herrtronic Humidifiers are manufactured under strict quality control guidelines and run through a series of tests. All circuit adjustments are made at the factory and should not be made in the field except under the direction of a factory representative. The following table is for your help and reference. If you still experience difficulty after trying these remedies, contact your Herrmidifier representative. The humidifier will automatically shut off if it detects any of the following:

**WARNING!**

The Herrtronic AD Series Electronic Humidifier cabinet was designed to house and shield the components from outside interference. Absolutely NO other components may be mounted inside or be electrically tapped into the humidifier without Herrmidifier's express written permission. Failure to heed this warning will void your warranty.

### UNIT DETECTED FAULTS:

Problem / Symptom	Probable Cause	Reason - Correction
<b>Overcurrent</b> The fault condition occurs when an overcurrent situation has occurred and the humidifier has shut down to prevent any damage. This fault is indicated by illumination of both the "fault light" on the front of the unit and L.E.D. CR17 on the circuit board. It indicates that there has been a significant reduction in resistance between the main legs of the power supply (both ADM and ADS) <b>and the humidifier should be serviced before it is restarted.</b>	Dead short between electrodes.	Replace the steam cylinder.
	Restricted or blocked drain.	Clean and inspect drain system.
	Restricted fill system	Clean and inspect the fill system. Check for restriction or loss of supply pressure.
	Incoming water conductivity is outside the range of normal circuit board settings.	Consult the factory for options.
<b>Cylinder Full Condition / End of Cylinder Life</b> This fault condition occurs if the humidifier is unable to satisfy the amp draw requirement over an extended period of time. This fault indicates a need to change the cylinder, that the water supply is low in conductivity, or that a foaming condition exists.	Fault occurs within first few hours of operation.	See start up note on jumper wire installation.
	Foaming condition exists.	Flush and fill that steam cylinder several times and restart. If it persists, you must filter or treat the water to remove the foam.
	End of Cylinder Life	Cylinder life is typically between 500 to 2000 hours, depending on incoming water supply. (See unit operation section for typical cylinder life expectancy chart.)
<b>Fill System Fault</b> This fault occurs when the fill solenoid has been energized for an excessive period of time. The humidifier has been shutdown to prevent any damage.	Defective fill solenoid	Repair or replace as required.
	Defective drain solenoid	Repair or replace as required.
	Loss of or restricted water supply	Check fill system.
	Leaking drain system	Check drain system.

**NOTE:** The three fault conditions outlined above will cause the humidifier to shut down and the service light on the front of the unit to illuminate. To clear these faults, the main power must be turned "off" and back "on" again.

### NON-FAULT ACTIVATED PROBLEMS:

Problem / Symptom	Reason - Correction
Water "foaming" inside cylinder energizes cylinder full light.	Check drain valve and insure that water drains freely. If necessary, clean or replace coil or valve if defective.
	Check water supply. If it is commercially softened, reconnect the unit to a raw water supply, drain the cylinder, and either restart the unit OR increase the drain threshold to 90%/ after draining the unit and restart. If the unit is connected to a hot water line, reconnect to the cold water supply.
	Observe the fill tee. If water is going down the overflow and the water level is low: <ul style="list-style-type: none"> <li>a. Check to insure that static pressure in the duct is not forcing water down the overflow instead of allowing the water to enter the cylinder.</li> <li>b. Adjust the metering valve on the fill solenoid to regulate the water flow to the cylinder.</li> </ul>
	Unit filling slower or at the same rate as it is boiling off causing over-concentration and foaming: <ul style="list-style-type: none"> <li>a. Fill rate must be increased. Open metering valve on fill solenoid.</li> <li>b. If "A" is not possible, get a water sample or water analysis and consult factory</li> </ul>
Main 24 volt fuses blow. "Fault" light comes on as soon as the humidifier is switched on.	Check the wiring at 24 VAC fuses for a short or loose connection.
	Check to make sure the capacity resistor is in main board socket R4.
	Remove contactor coil from circuit and repeat. If 24 VAC fuses don't blow, replace contactor.
Main 24 VAC fuses blow after humidifier is turned on for about 15 seconds	Remove fill solenoid from circuit. If fuses remain intact, replace the fill solenoid coil.
	Replace the main circuit board
Humidifier goes into fault shortly after start-up.	Check amp draw to unit on initial start-up. If reading exceeds amp rating by more than 20%, the low drain threshold, pot (Figure 23) on the circuit board should be increased 2% on ADM's and 5% on ADS' to cause the unit to drain more frequently and hence reduce the conductivity of the water in the tank. Manually drain humidifier and restart.
	Turn the capacity adjustment pot slightly counterclockwise. This will provide a buffer between the unit normal amp maximum and the overload amp level, a necessity with extremely conductive fill water.
	Obtain a water analysis and consult the factory.
	Check the fuses.
Main fuses blow when the drain valve activates.	Open the drain valve and insure that it is clean and free of any obstructing mineral deposits.
	Remove drain solenoid from circuit. If fuses remain intact, replace the drain solenoid coil.
	Replace the main circuit board
Humidifier turned on, but will not operate	Check fuses and replace if faulty
	Insure that 24 VAC is reaching pole #9 connector J1 (Figure 23). If not, check wiring.
Unit turned on. Contactor is pulled in, but not water enters the cylinder.	Check external shutoff valves and open if closed.
	Check that fill solenoid coil is receiving 24 VAC. If yes, replace the solenoid.
	Check for break in wiring
	Replace the circuit board

**NON-FAULT ACTIVATED PROBLEMS – CONT'D:**

<b>Problem / Symptom</b>	<b>Reason - Correction</b>
Unit turned on. Unit cycles properly for short period of time. Then it stops in the middle of a fill cycle and won't reset until boiling stops.	Check cylinder full interface connections. Make sure terminal
	Check cylinder connections (See Figure #11)
	Check items in next troubleshooting tip concerning foaming.
	Check amperage between cylinder full electrode and cylinder full interface terminal #1. If it is greater than 7.0 mA AC, take a fill water sample and consult the factory.
Water "foaming" inside the cylinder.	Check drain valve and insure that water drains freely. If necessary, clean or replace valve if defective.
	Check water supply. If it is commercially softened, either increase the drain threshold (R18) to 92% or reconnect the unit to raw water. Drain and restart the unit. If the unit is connected to a hot water line, reconnect to the cold water line.
	If steam line is hard copper, drain cylinder and test unit operation disconnected from steam line to insure flux from solder joints is not causing foaming.
	Observe the fill tee(GT-120). If water is going down the overflow and the water level is low: <ul style="list-style-type: none"> <li>• Check to insure that static pressure in the duct is not forcing water down the overflow instead of allowing water to enter the cylinder.</li> <li>• Adjust the fill metering valve to regulate the water flow to the cylinder. ( Figure 9)</li> <li>• Unit filling slower or at the same rate as it is boiling off, causing over concentration and foaming. Fill rate must be increased. Open metering valve.</li> <li>• If the fill valve is already fully open, get a water analysis and consult the factory.</li> </ul>
Cylinder fills and overflows	Check cylinder wiring (See Figure #11)
	Check wiring of cylinder full interface.
	If more than 1.9 mA AC is passing between the cylinder full electrode and interface terminal #1, and when placing multimeter between terminal #3 and ground yields approximately negative 11 VDC, replace the interface.
	Replace the circuit board.
	Consult the factory after obtaining a water analysis
Unit turned on, fills to full amp draw, stops filling, and after a delay, the circuit breaker trips and the service light comes on.	Use the "On-Off Drain" switch to drain the cylinder. Turn the capacity adjustment pot(R39) on the main circuit board to 80% and restart the humidifier.
	Check the drain valve and clean or replace if necessary.
	If the drain valve doesn't come on before the service light illuminates, replace the main circuit board.
Unit cycle "on" and "off" rapidly	Check location and setting of high limit humidistat
Cabinet leaks	Check for loose connections
	Fill tube out of fill tee
	Steam cylinder out of drain cup
	Cabinet drain backing up, kink in drain line

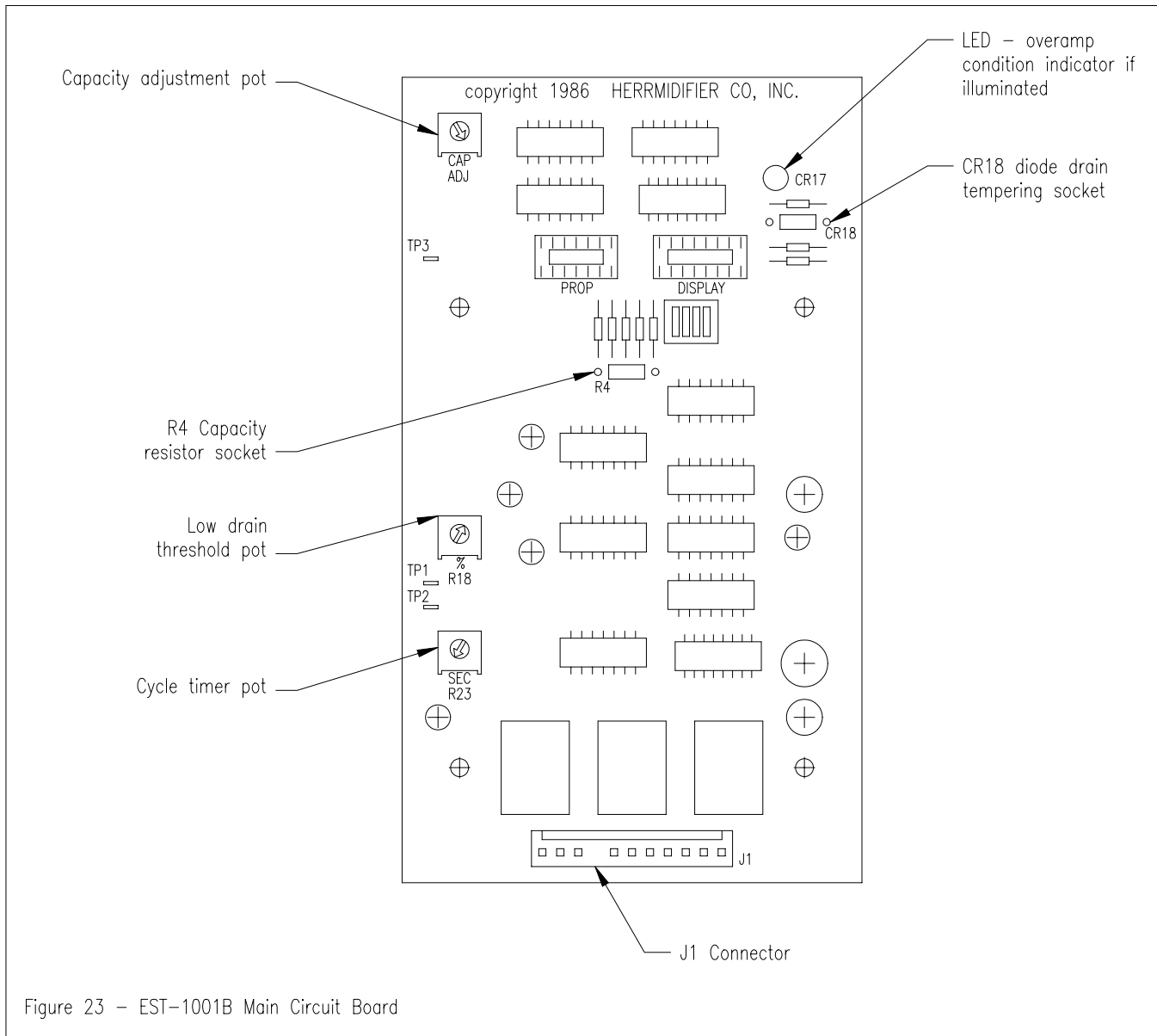

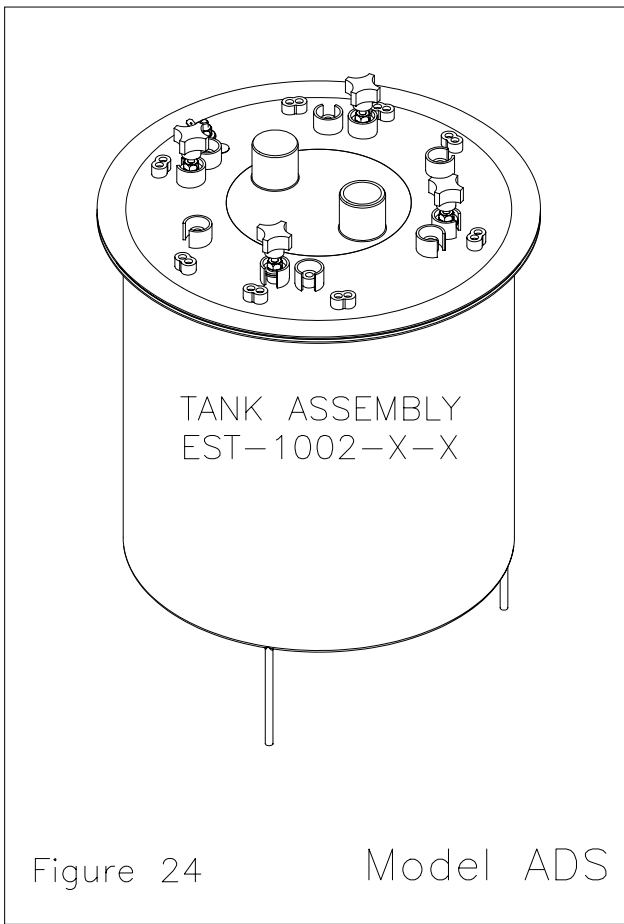

**Parts List**

**Item NO.**

**Description**

**Steam Cylinder Assemblies:**

**ADS**

EST-1002-4-1

Single Phase, 5 62#/hr.

EST-1002-6-1

Three Phase, 5 62#/hr.

EST-1002-6-2

Three Phase, 60-125#/hr.



**Parts List**

**Item No.**

**Description**

**Steam Cylinder Assemblies:**

**ADM**

EST-416-2

Single Phase, 5-15#/hr.

EST-416-3

Three Phase, 5-30#/hr.

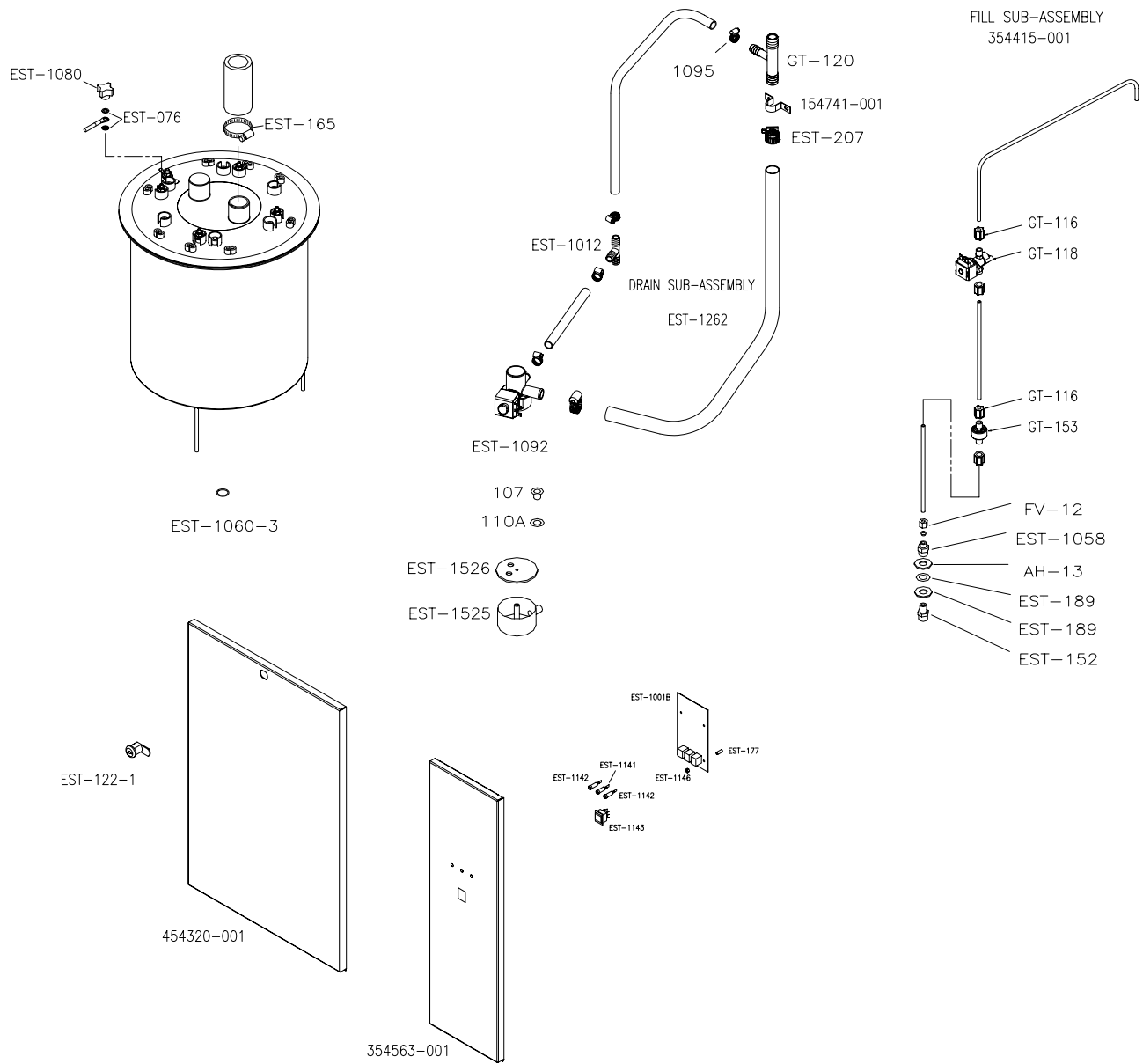

# Model ADS - Parts Schematic

Fig. 1

AD-LFG-1-1

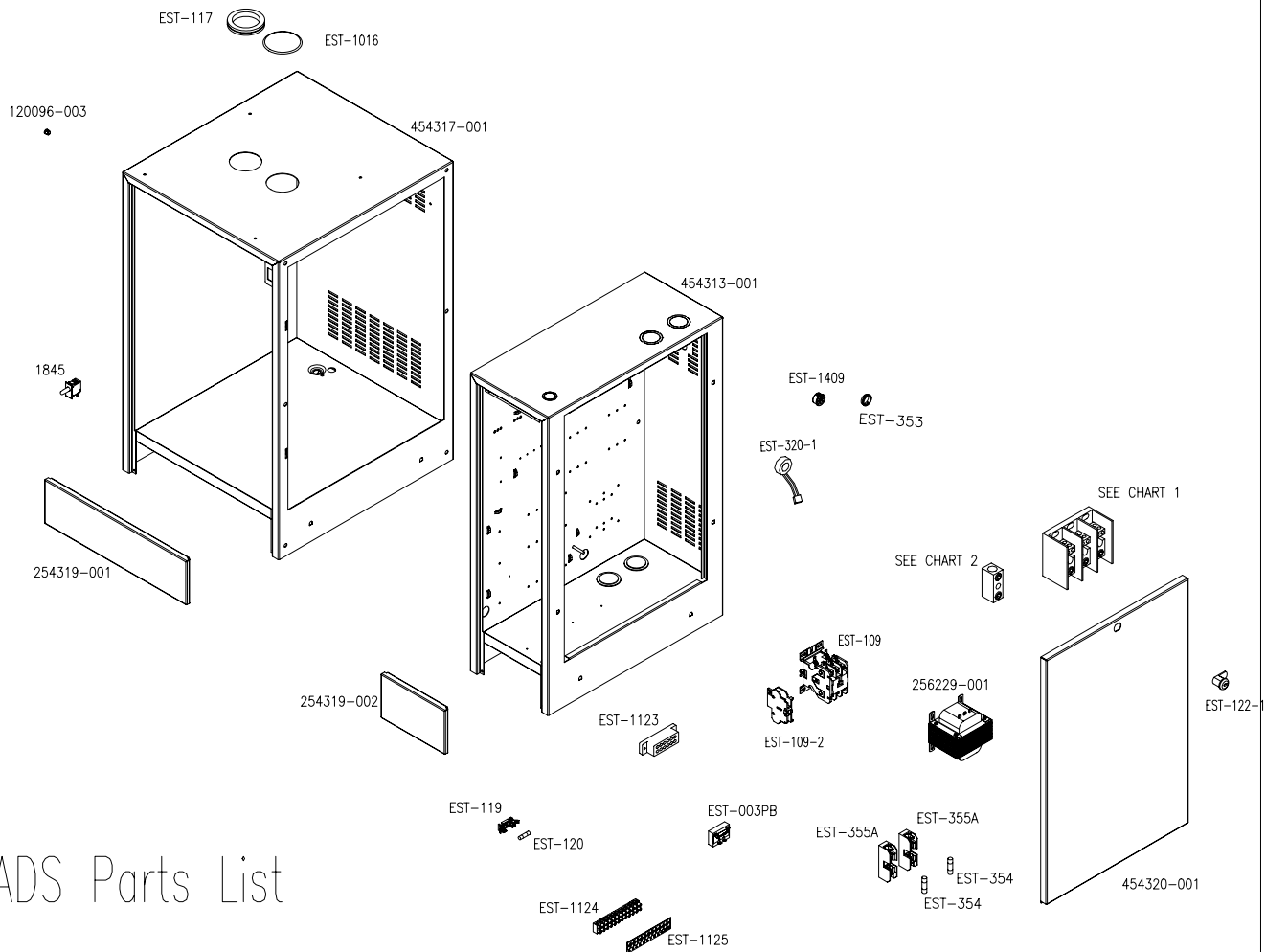

# ADS Parts List

TRION PART NO.	DESCRIPTION
EST-003	Cylinder Full Interface
EST-109	Contactor, 3 Pole, 40 Amp
EST-109-2	Auxiliary Contact
EST-109-3	Contactor, 3 Pole, 65 Amp
EST-117	Grommet, Steam Hose
EST-119	Fuse Holder
EST-120	Control Fuse, 4 Amp
EST-122-1	Cabinet Lock with Keys
EST-152	1/2" Comp. X 1/4" MPT Brass Adt.
EST-165	SS Hose Clamp, Steam Hose
EST-171	Steam Hose
EST-189	Brass Washer
EST-207	Clamp
EST-235	Power Distribution Block, 175A, 1PH
EST-236	Power Distribution Block, 175A, 3 PH
EST-238	Ground Block
EST-239	Ground Block
254554-001	Toroid Transformer
EST-353	Shorty Bushing, 7/8"
EST-354	High Voltage Fuse, 600 V
141622	High Voltage Fuse Holder
EST-529C	Quick Connect, Cyl Full Electrode
EST-1012	Drain Tee, 1/2"
EST-1016	Hole Plug, Steam Outlet, 2 1/2"
256229-001	Main Line Transformer
1845	Door Interlock Switch

TRION PART NO.	DESCRIPTION
EST-1058	Female Connectors, 1/4" Comp. X 1/4 FPT
EST-1060-3	"O" Ring
EST-1080	Electrode Knob
EST-1092	Drain Kit Assembly (includes Solenoid and Drain Cup)
EST-1123	Terminal Block, 12 Position
EST-1124	Terminal strip, 4 Amp
EST-1125	Marking Strip for EST-1124
EST-1127	Spacer, Nylon #6
EST-1136	Spacer, Nylon #4
EST-1168	Ribbon Cable Assembly
EST-1001	Microprocessor Board, Provide Specific Model # and Control Arrangement.
121800-001	KEP NUT, 4-40
EST-1525	Drain Reservoir
EST-1526	Gasket, Drain Reservoir
AH-13	Rubber Washer
FV-12	Brass Comp. Nut, 1/4"
GT-116	Celcon Comp. Nut, 1/4"
GT-118	Metering Fill Solenoid
GT-120	Fill Tee
154741-001	Hose Clamp
GT-153	Strainer
107	Brass Cabinet Drain Eyelet
110A	SS Retaining Ring
1095	SS Hose Clamp

FIG. 2

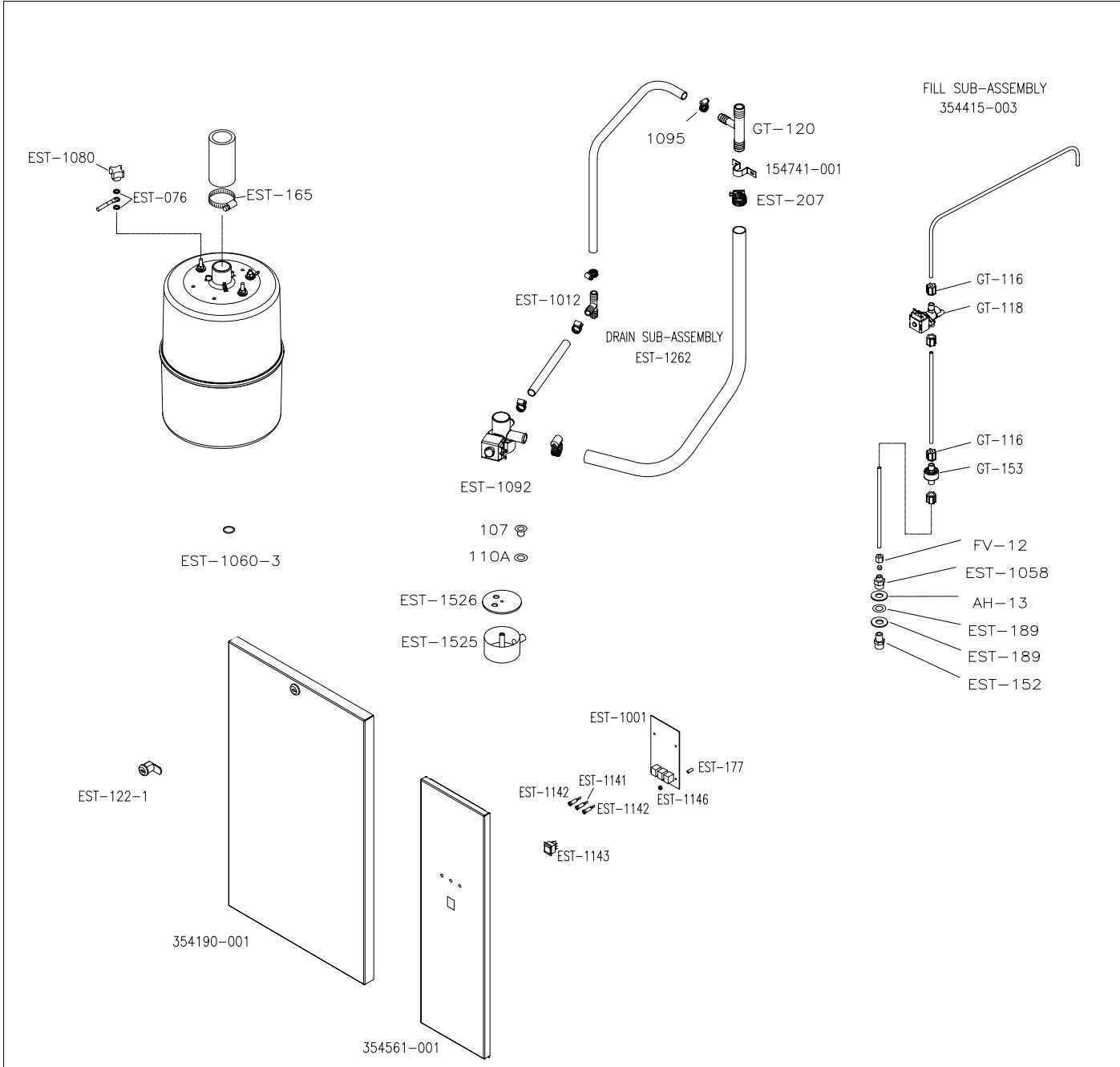

# Model ADM - Parts Schematic

Fig. 1



# AD WIRING DIAGRAM

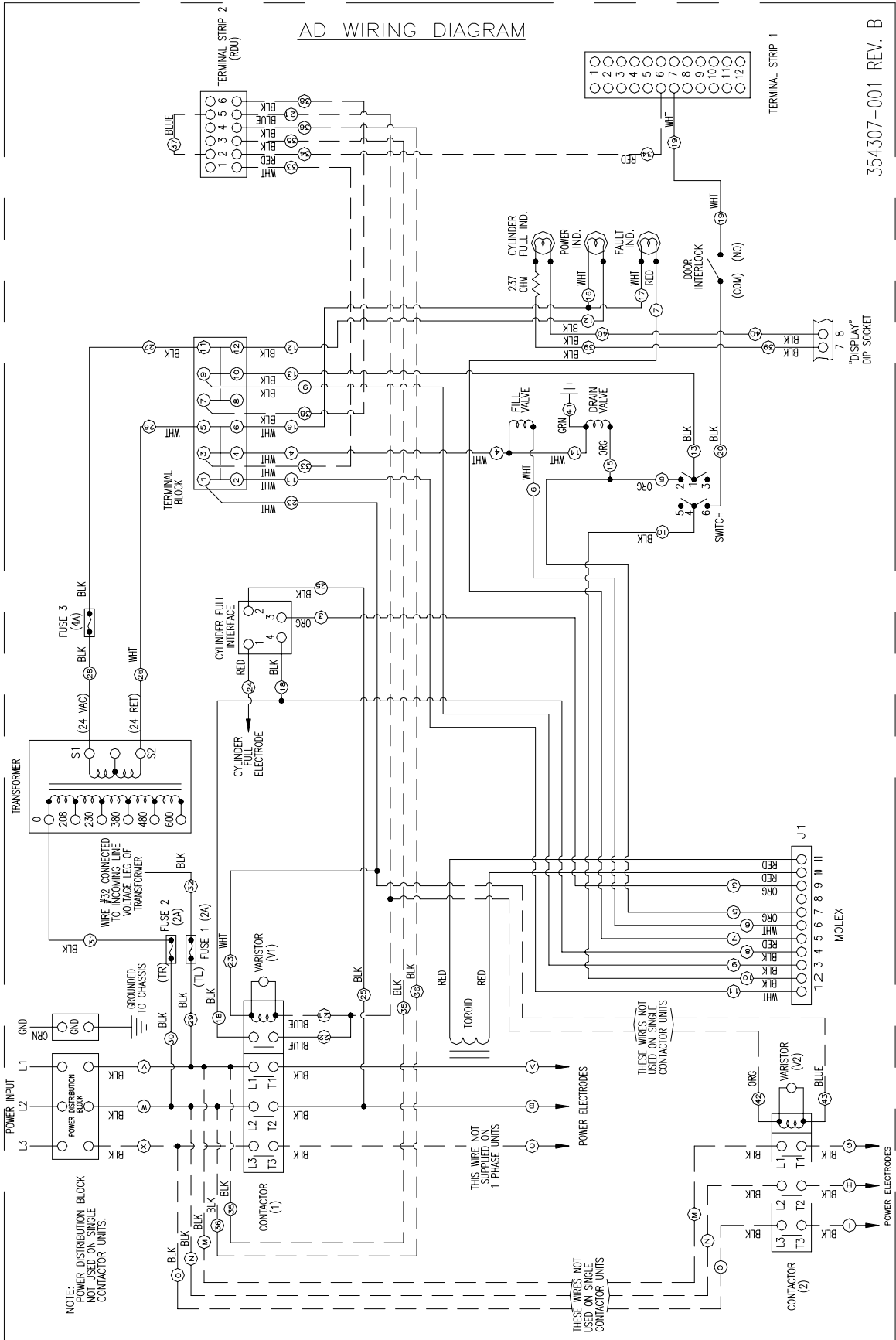

354307-001 REV. B



A **FEDDERS** INDOOR AIR QUALITY COMPANY

**Corporate Office:** 101 McNeill Road • Sanford, NC 27330  
**Phone:** 800-884-0002 • **Fax:** 919-777-6300 • **www.herrmidifier.com** • **email:**  
herrsales@trioninc.com

Part No. 156573 • ©2003, Trion, Inc. • Effective 5/03 • Subject to change without notice