

## EAC9-14 (1400 CFM) AND EAC9-20 (2000 CFM) SERIES AIR CLEANERS

### 1 — UNIT INFORMATION

#### A — Assembly

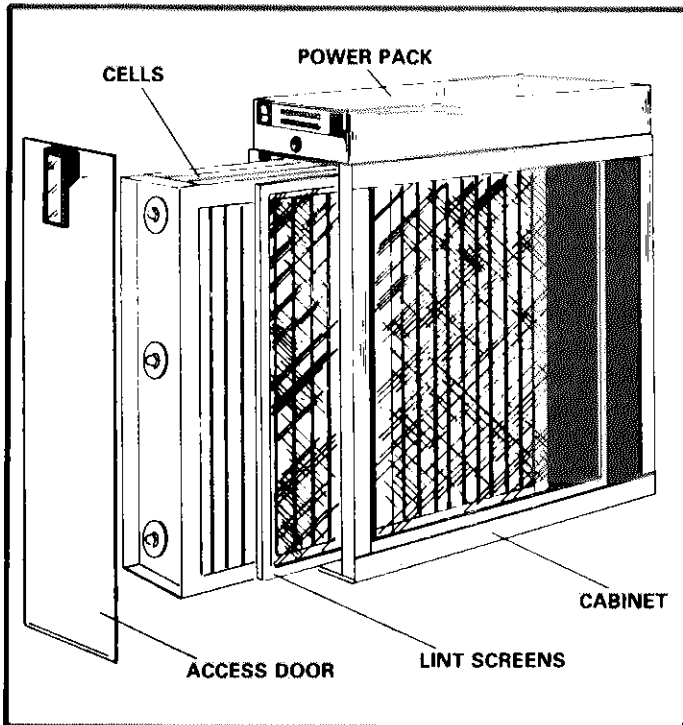

#### B — Air Resistance

Air Volume (Cfm)	Total Resistance (in. wg)	
	EAC9-14	EAC9-20
600	.03	---
800	.04	.03
1000	.05	.04
1200	.07	.05
1400	.09	.07
1600	---	.09
1800	---	.12
2000	---	.14

NOTE — Standard central system filter is removed and not included in table.

#### C — Specifications

Model No.	EAC9-14	EAC9-20
Electronic cell (in.) total	(2) 16 x 12-3/8 x 5-1/8	(2) 20 x 12-3/8 x 5-1/8
Pre-filter (in.)	(2) 16 x 12-3/8 x 5/16	(2) 20 x 12-3/8 x 5/16
Maximum watts	35	35
Air volume range (cfm)	600 — 1400	800 — 2000
Shipping weight (lbs.)	43	49
No. of packages in shipment	1	1
Electrical characteristics	120 volts — 60 hertz — 1 phase	

## D – Dimensions

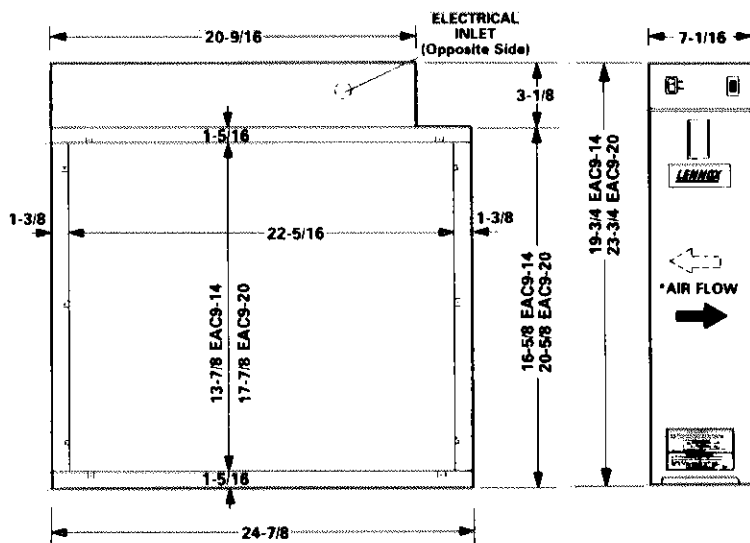

\*NOTE – Air flow may be reversed by relocating protective pre-filters and electronic cells.

## E – Principle Of Operation (Figure 1)

- 1 - The EAC9 is technically known as a two-stage, single voltage, electrostatic precipitator. It is designed to remove airborne particles from the air.
- 2 - Air movement through the unit is controlled by the heating and/or air conditioning system in which it is installed. As dirty air enters the unit it passes through a lint screen. The resistance offered by the lint screen provides for an even distribution of the incoming air and strains out the larger particles of dirt by direct impingement.
- 3 - The prefiltered air then passes through a two-stage electrostatic precipitator. In the first stage of electrical operation, all airborne particles, even of submicroscopic size, are electrically charged (positive) as they pass through the ionizer where a high concentration of ions emanate from fine tungsten wires (A) suspended between grounded electrodes (B). In the second stage of operation,

the charged particles pass into an electrical field established between a series of parallel plates. Here the positively charged particles are attracted to the plates, (D) forming the negative element of the field. The field is created by placing a positive charge on each alternate plate (C) in the series while the interleaving plates are relatively negative or electrically grounded.

- 4 - Periodically, the pre-filter and the ionizing-collecting cell are removed from the cabinet and the collected dirt is manually washed away. The frequency of the washing operation is dependent upon the type and amount of dirt subjected to the unit. The cleaning schedule is best determined by visual examinations when initially placed into service.

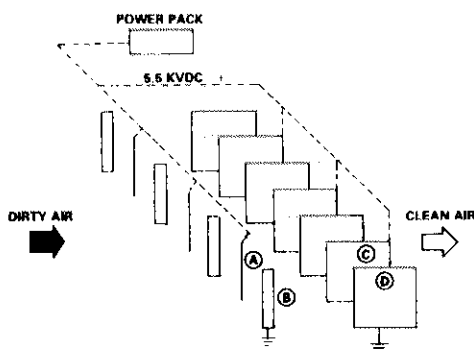

FIGURE 1

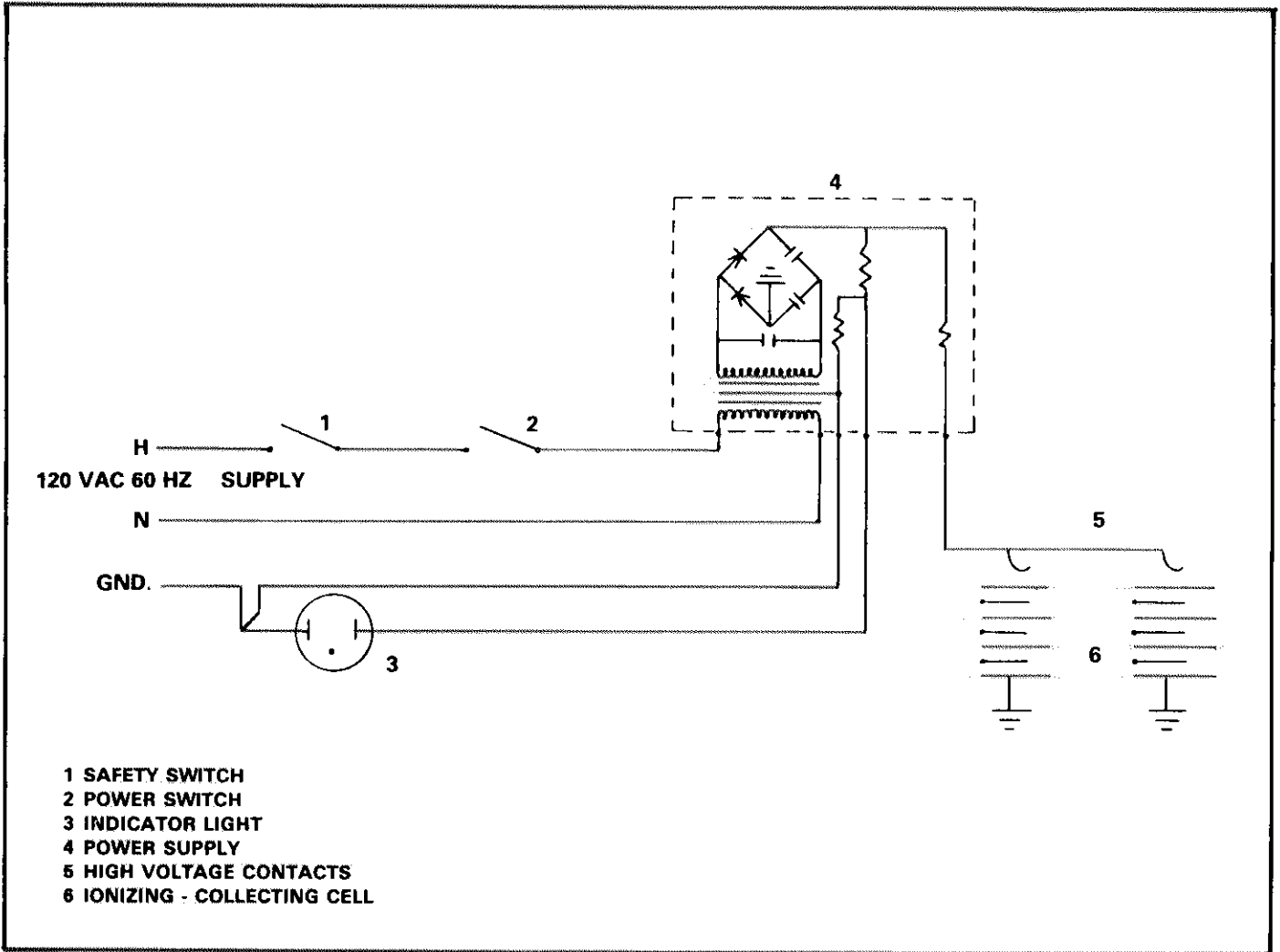

FIGURE 2

**F — The Electrical Circuit (Figure 2)**

1 - **PRIMARY:** The EAC9 Electronic Air Cleaner should be wired to operate only when the system fan is running. In the primary circuit of the power pack, 120 volts, 60 cycle single phase, alternating current enters the power supply (4) through a safety switch (1) and power switch (2). The safety switch opens the circuit to the power supply when the access door is removed, preventing access to the collecting elements without first interrupting all power.

2 - **SECONDARY:** In the secondary circuit the primary AC is "stepped up" and converted to DC. The circuit is a full wave voltage doubler; that is, the output of the power supply is approximately two times that of the transformer. This is accomplished by alternately charging two capacitors through two rectifiers. The voltage stored by both capacitors combines in series to double the transformer voltage which is the required working voltage for the ionizing-collecting cells (6).

The secondary voltage is wired to the ionizing-collecting cells through a surge resistor which protects the capacitors from extreme voltage surges caused by the normal arcing which occurs in precipitators.

3 - The secondary voltage is monitored by an indicating light (3) which is connected to the circuit through a "dropping" resistor. A "bleeder" resistor connected across ground and the dropping resistor bleeds off any residual power stored in the capacitors or ionizing-collecting cell when the circuit is de-energized.

**G — Recommended Service Tools**

- 1 - Test Light  
120 VAC Neon
- 2 - Screw Driver  
8" Common with plastic handle
- 3 - Needle Nose Pliers
- 4 - Ohmmeter  
10,000 (Plus) OHM Range
- 5 - Kilovolt Meter  
10,000 (Plus) KVAC Positive Polarity Range

## H — Most Common Areas Of Trouble

- 1 - There are two areas in which the majority of service problems originate:
  - A. The Ionizing-Collecting Cell
  - B. The Power Supply
- 2 - The cell, which is removed from the unit periodically to wash away the collected dirt, is more susceptible to physical damage through handling, than the power supply. The cell also contains one component, the ionizing wires, which due to their function, have to be designed with a minimum of structural support and therefore susceptible to some expected breakage.
- 3 - The power supply, like other electrical items exposed to "high voltage" is susceptible to the usual stresses.
- 4 - Trouble related to either of these two items is readily shown by the indicating light and can be easily and quickly isolated to one, or the other, by a simple procedure. Refer to: Section II - B, Isolating Electrical Trouble to a Major Component.

## II - TROUBLESHOOTING

### A - Indication Of Electrical Trouble

- 1 - The indicating light is wired into the circuit so that it will monitor both the primary and secondary circuits. (Electrically, the ionizing-collecting cell is a component in the secondary circuit.)
- 2 - When the unit is in normal state of operation, system fan running, access door in place, control switch in "on" position, and the indicating light goes "out," there is an electrical problem. The problem may be either a shorted secondary or an open primary circuit. Although the failure of the indicating light itself should not be overlooked, this condition is unusual and rather remote. The light is neon and fairly reliable.

### B - Isolating Electrical Trouble To Major Components

- 1 - When the unit is in normal state of operation and the indicating light goes "out," the trouble can be readily isolated to either the ionizing-collecting cells or power pack. Turn the unit "off," remove both ionizing-collecting cells, close the access panel and turn unit "on." If the light remains "off" with the cells removed the trouble is in the power supply or in the primary circuit to the power supply. (Refer to Section II - C-1, Power Supply).

### C - Electrical Troubles & Their Corrections

#### CAUTION:

- (1) Exercise the usual precautions when working with high voltage.
- (2) When the circuit has been de-energized always discharge any residual current in the secondary with an insulated handle screwdriver.
- (3) Always ground power supply and ionizing-collecting cell when bench testing.

#### 1 - Power Supply:

If there is primary power to the power supply and the secondary output voltage is absent or low, the power supply is defective. A fast simple check can be made by drawing an arc, with an insulated handle screwdriver between common ground, (power pack housing) and the hi-voltage output terminal. A good power supply will produce a pronounced arc where a defective one will produce no arc at all or a very weak one. (Refer to Figure 3, Power Supply Test for more detailed information).

#### 2 - Primary Circuit:

If there is supply line voltage at the service connections and no input voltage to the power supply, the outage can be located by checking operation of the safety switch and control switch as well as the interconnecting wiring, with a 120 volt test light.

Refer to circuit diagram, Figure 3. If there is power to the line side of either switch, and no power on the load side when the switch is closed the switch is defective and should be replaced.

#### 3 - Ionizing-Collecting Cell:

The cell is electrically energized through a contact terminal located at the top center of cell. The ionizing wires and every other collector plate are electrically charged while each interleaving plate is grounded.

If the space between the charged and ground components is bridged with conductive or semi-conductive material, a short circuit develops. The bridging or short may be caused by broken components or foreign material lodged between or on the components.

Most troubles in the cell can be readily detected visually.

CAUSES	CORRECTIONS
Excessive dirt build-up	Wash
Large pieces of foreign matter lodged between plates	Remove
Very dirty insulators	Clean
Broken ionizing wires	Remove all pieces of broken wires and replace
Excessively bent or misaligned components due to mishandling	Straighten or replace
Externally broken or cracked insulators	Replace
*Internally defective insulators	Replace

\*Although uncommon, an insulator will occasionally short out internally. There may be no visual flaws evident on the external surface. It may have a very definite discoloration underneath the surface however, or show green deposits built up near the center securing fastener. Also if the conditions are right the defect can be located by touch. When the cell has been DE-ENERGIZED and REMOVED from the cabinet the insulator that is warm to the touch will be defective.

**POWER SUPPLY TEST**

Power Supply Part No. 88C4601  
 Used on Unit Part No.'s - EAC9-14 & EAC9-20

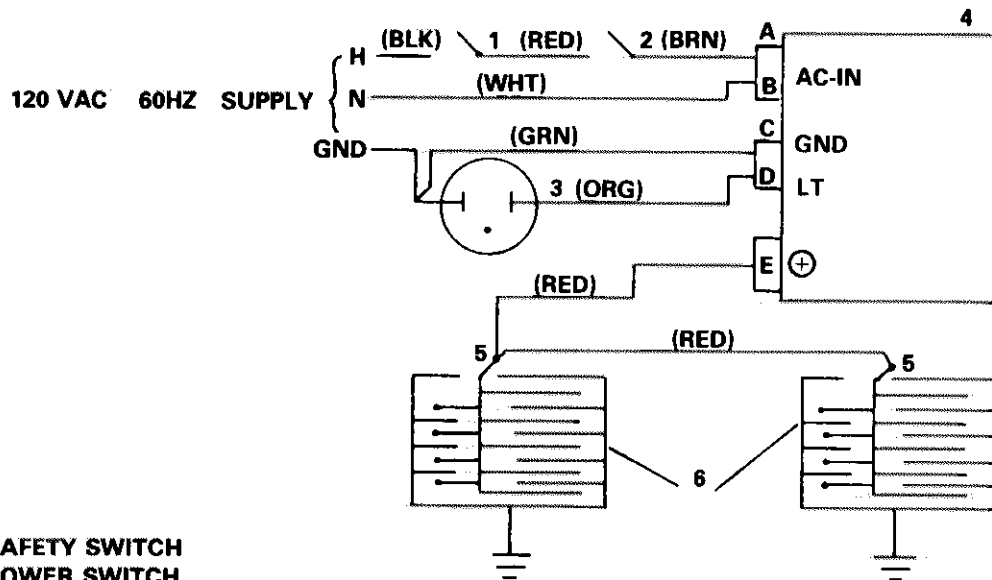

- 1 SAFETY SWITCH
- 2 POWER SWITCH
- 3 INDICATOR LIGHT
- 4 POWER SUPPLY
- 5 HIGH VOLTAGE CONTACTS
- 6 IONIZING - COLLECTING CELL

**WARNING: WHEN BENCH TESTING POWER SUPPLY, ALWAYS ATTACH GROUND WIRE.**

The following are approximate DC output voltage at 120 VAC.

TEST POINTS	SECONDARY DC VOLTAGE
(E) TO (C)	7800 VDC + 200 V (Cells disconnected)
(E) TO (C)	6400 VDC + 300 V (Cells connected)
(D) TO (C)	75 VDC + 10 V (Light connected)
(D) TO (C)	115 VDC + 20 V (Light disconnected)

The following are approximate values. ± 20%

TEST POINTS	RESISTANCE
(A) TO (B)	22 Ohms
(C) TO (D)	2.2 Meg Ohms
(C) TO (E)	102 Meg Ohms

FIGURE 3

## D - Other Problems, Symptoms & Their Corrections

### 1 - Arcing Noise:

When an arcing noise is noted, it is usually located in the DC high voltage circuit. The ionizing-collecting cell is part of this circuit and normally the trouble will be found to be in the cell. The noise is caused by the high voltage arcing to ground.

An occasional arcing noise is normal and inherent in all precipitators. These occasional arcs are caused by large particles of dirt in the air such as a cigarette ash, insect, etc. Constant or repeated intermittent arcing should be checked.

Check For:

- (A) Loose ionizing wires(s) - Repair or replace
- (B) Excessively dirty cell components - Clean
- (C) Damaged (bent) plates of ionizer - Straighten or replace
- (D) Defective or loose high voltage lead or contact assembly - Repair, replace
- (E) Cracked insulator - Replace
- (F) Improper ground - Check ground and correct if necessary

### 2 - Hissing Noise

A hissing noise (or frying) usually stems from a loose high voltage connection or from a reduced spacing between a charged high voltage component and ground. The reduction in the designed spacing usually is caused by bends or deformities in the cell from mishandling.

Check For:

- (A) Damaged (bent) plates or ionizer - Straighten or replace
- (B) Loose ionizing wires - Repair or replace
- (C) Dirty cell or large piece of foreign material between plates - Clean
- (D) Defective high voltage contact assembly - Repair or replace
- (E) Poor connection between cell and contact assembly - Repair
- (F) Loose high voltage wiring - Repair
- (G) Improper ground - Check ground and correct if necessary

### 3 - Humming Noise:

The ionizing wires have a normal tendency to vibrate when charged. On some occasions, when atmospheric conditions are just right and the humidity is exceptionally low the vibration is aggravated to the point where an audible hum can be noted. It is usually noted more in the Northern sections of the country during the winter months. This condition can be further aggravated if the ionizing-collecting cell is very dirty. The condition is self correcting when the relative humidity is increased or can be alleviated by washing the cell.

### 4 - Radio and/or Television Interference:

This trouble is not common but when occurring is usually due to a continuous high voltage "leak or discharge." Also, from the absence of a good common electrical ground. Refer to checks listed under 1. Arcing Noise and 2. Hissing Noise.

### 5 - Air Not Being Cleaned:

Be sure EAC9 unit is operating when the air handling unit is operating.

- (A) Air volume through unit too great - Reduce air flow to the maximum designed CFM rating.
- (B) Leaks in ductwork on blower box and other parts of system under negative pressure on clean air side of EAC9 unit - Seal with duct tape or caulking compound.
- (C) Dirty air not being delivered to EAC9 unit. Common cause in residential units is the blocking of return air grill with drapes, furniture, etc. - Remove obstruction.
- (D) Uneven air distribution across the face of the ionizing-collecting cell - \*the lint screen tends to even out the air but for extremely close angle entrances install turning vanes, air baffles or provide means for even air distribution.

\*Uneven air distribution across the face of the ionizing-collecting cell may be determined in many instances by examining the dirt pattern before washing. The entering side of the cell should be covered evenly with the dirt collected.

NOTE: Dirt build-up on the ionizing-collecting cell or after filter should not be confused with dirt stains. Dirt stains are normal and do not effect efficiency.

### 6 - White Dust:

One of the most difficult service calls to handle is the complaint of the presence of white dust in ionized areas. The majority of these complaints are from residential users. In many instances, the statement is made, "We have more dust now than we ever had." These service calls are difficult because the limitations of the installation must be explained.

White dust actually can be described as "clean dirt." Where it is noticed, an examination will show the user that it is largely lint. It is most noticeable on dark furniture, and is usually found in homes containing new furnishings such as carpeting, drapes, etc., which give off more lint than such items that have been used and cleaned for some time. The amount of lint generated is increased by activity in the areas; especially by children, pets and heavy house traffic.

Visible lint particles, like cigarette ashes, are heavy as compared to the extremely small, individual dirt particles which make up cigarette smoke. Their weight causes the lint particles to "fall-out" on furniture, floors, etc., just as cigarette ashes fall to the floor while cigarette smoke particles remain suspended in the air. Dirt particles, such as heavy pieces of lint or ash, which do not remain air-borne, never reach the EAC9, and the unit cannot remove these air particles which never reach the collecting elements.

Fortunately, the black, greasy dirt particles with the damaging staining power are light in weight, remain in the air stream, and do not reach the EAC9. It is their removal from the air that keeps the lint clean, and therefore, more visible.

There is no question that the EAC9 is capable of collecting lint in addition to other atmospheric contaminants. This is easily confirmed by examining the air entering side of the ionizing-collecting cell before it is washed. You will note that along with the black, greasy dirt collected, there are lint particles that did stay airborne long enough to reach the EAC9.

Lint from new furnishings will decrease with wear. The length of time depends on the amount and type of fabric in the furnishings and the air circulation. In some areas, a bedroom for example, a lint condition will always remain.

Normally, continuous fan operation (24 hours a day) will minimize this problem. If this cannot be accomplished, the controls should be set for as near continuous fan operation as possible. In some instances the use of a two speed fan motor is advantageous.

Cold air returns should not be restricted in any manner, particularly from rooms in which lint is prevalent. If the returns in these rooms are blocked, the return air will seek another, longer path. In traveling a greater distance, lint fall-out is increased.

Actually, the presence of large, clean lint particles are further proof that EAC9 is doing its superior air cleaning job. Electronic air cleaners are dependent on the movement of air currents to bring the dirt particles to the unit for their removal. Weighty, non-airborne particles such as cigarette ashes weigh too much to remain in the air currents while other particles, such as cigarette smoke, remain suspended and are carried to the EAC9 for removal.

#### 7 - Ozone:

Under normal operating conditions all electrostatic air cleaners produce minute quantities of ozone. The design of the unit has been tested and is far below the published permissible limits. The level of detection (when it is noticed) varies from individual to individual, some being more susceptible than others.

Usually a new unit will produce more ozone than one that has been in operation for several weeks. This is due to the normal amount of sharp corners or manufacturing burrs on the ionizing-collecting cell causing points of voltage concentration on which in turn produce ozone. The voltage working on these areas however, tends to round them off, thereby they are self correcting.

An ionizing-collecting cell that has been damaged, where in the designed spacing between electrically charged and ground components has been decreased, may also produce an abnormal amount of ozone.

Check For:

- (A) Damaged (bent) plates - Straighten or replace
- (B) Loose ionizing wires - Repair or replace
- (C) Dirty Cell - Clean
- (D) Loose high voltage connections - Repair or replace
- (E) EAC9 "on" when system fan is not running - Set fan for continuous operation or wire in accordance with Installation Manual so as EAC9 will operate only when system fan is running.

### III - MAINTENANCE & WASHING

Listed below are the instructions as stated in the Owners Manual.

#### A - Maintenance

- 1 - When to Wash: Periodically the dirt collected by your unit must be removed. The frequency of washing will depend on the amount of dirt present in the air in your locality.
- 2 - Frequent washings are in no way harmful to your unit, but prolonged use without cleaning will decrease its dirt collecting ability.
- 3 - The washing frequency best suited for your unit can be determined by examining the dirt collecting components at three week intervals. As the dirt begins to collect, you will notice a light film, then a very definite collection will be evident at a later examination. When there is a noticeable build-up of dirt, it is time to wash.
- 4 - Generally, the lint screen located on the air entering side of the cabinet, will require cleaning more often than the ionizing-collecting plate section. This is due to the collection of the larger particles of dirt such as lint, animal hairs, etc., which tend to build-up faster than the smaller particles that pass into the collecting plates. The washing schedule could, therefore, be as follows:
  - a) Lint Screen - once every four weeks.
  - b) Ionizing-Collecting Cells - once every eight weeks.

#### B - Steps For Washing

- 1 - Turn control switch "OFF."
- 2 - Remove door, slide out lint screen and cells and install door.
- 3 - To facilitate washing place components in automatic dishwasher, stationary tub, shower stall or over floor drain. Use hot soapy water and rinse thoroughly. As an aid to drying, rinse with clear hot water. Allow components to dry thoroughly.
- 4 - Remove door and slide lint screen in retaining channel on air entering side of cabinet.
- 5 - Slide cells into cabinet with directional "air flow" arrow pointing in direction of air flow.
- 6 - Replace door.
- 7 - Turn control switch "ON."
- 8 - If arcing noise occurs due to wet cells, turn control switch "OFF" and allow more drying time.

### E - Quick Reference Trouble Chart

CONDITION OR SYMPTOM	TROUBLE DESCRIPTION	PROBABLE LOCATION	PROBABILITY	POSSIBLE CAUSE	CORRECTION
Indicating Light Out	Short Circuit	Cell	Good	Broken Ion Wire Excessive Dirt Object Between Plates Damaged (Bent) Plates Damaged (Bent) Ionizer Broken Insulator	Remove & Replace Wash Remove Straighten or Replace Straighten or Replace Replace
Indicating Light Out	Short Circuit	Power Supply	Fair	Defective Power Supply	Replace
Indicating Light Out	Light Out But Unit Working	Indicating Light	Remote	Defective Light	Replace
Indicating Light Out	Open Primary Circuit	Primary Wiring	Fair	No Power at Service Connection Access Panel not closed Bad (Open) Safety Switch Bad (Open) Control Switch Transformer (Open) Wiring Loose Wiring	Obtain Power Close Replace Replace Replace Repair
Cracking Noise & Flickering Indicating Light	Objectionable Noise	Cell	Occasional	Loose Ionizing Wire Dirty Cell Damaged (Bent) Plates Damaged (Bent) Ionizer	Replace Wash Straighten or Replace Straighten or Replace
Loud Hissing Noise	Same	Cell or Hi-Voltage Connection	Occasional	Dirty Cell Loose Hi-Voltage Connection	Wash Correct
Radio and/or TV Interference	Same	Same as above	Not Often	Improper Ground Loose Hi-Voltage Connection	Correct Correct
Air not being cleaned	Same	----	Not Often	See Page 6	----
Odor of Ozone	Same	----	Not Often	See Page 7	----