



“Read and Save These Instructions”

Deionized, Demineralized, or Reverse Osmosis Water

“ECDDR” Series Electric Humidifier

Installation Instructions

Operation and Maintenance Manual

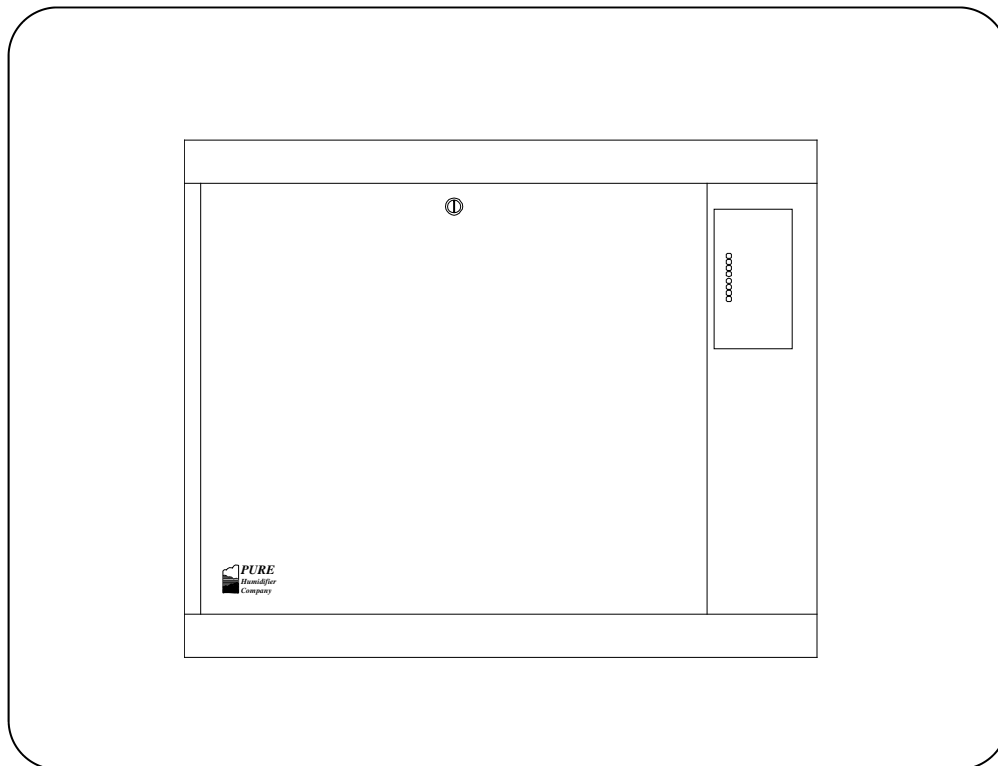

Our results are comforting

Form No: ECOM-08-08



Introduction

To the user of PURE Humidifier Co.'s Electric Humidifiers

We at PURE Humidifier Co. thank you for choosing one of our quality products. PURE Humidifier Co. electric series humidifiers are models of simplicity to install, operate, and maintain. However, they must be maintained to provide maximum operating efficiency.

PLEASE READ AND FOLLOW ALL INSTRUCTIONS CAREFULLY. PROPER OPERATION AND HUMIDITY CONTROL IS POSSIBLE ONLY WITH PROPER INSTALLATION AND MAINTENANCE.

The "ECDDR" Series Humidifier is specifically designed to operate with deionized, demineralized, or reverse osmosis water. All components that will be in contact with water are constructed of type 304 stainless steel, incoloy, or corrosion resistant materials.

Use of mineralized (hard or soft) tap water will cause fill valve failure and void that warranty. PURE Humidifier Co.'s "EC" Series should be installed on applications that require tap water.

High chloride content in feed water can cause chloride stress cracking and chloride pitting in stainless components. Chloride stress corrosion cracking (CSCC) and chloride pitting of stainless steel components is not covered by warranty. Do not use hydrochloric acid descalers or bleach to clean the tank. Consult the factory if you are unsure about which chemical descaler to use.

To ensure proper installation of this product, it must be installed by qualified HVAC and electrical contractors, and must be in compliance with local, state, federal, and governing codes. If installed improperly this product may cause damage to property, severe personal injury, or death as a result of electric shock, burns, and/or fire.

The PURE Humidifier Co. Warranty

PURE Humidifier Co. guarantees its products to be free from defects in material and workmanship for a period of one year from the date of shipment; provided the product is properly installed, serviced, and put into the service for which it was intended.

PURE Humidifier Co. is obligated under the terms of this warranty to the repair or replacement of the defective part(s), excluding any labor charges, or to refund the purchase price at our option. PURE Humidifier Co. assumes no obligation for incidental or consequential damages. The above provisions are in lieu of all other guarantees, obligations, liabilities or warranties, expressed or implied.

Table of Contents

Introduction	1
Internal Humidifier Features	1
Capacity & Electrical Specifications	2
Layout and Dimensions	3
Humidifier Layout	4
Mounting/Location	5
Wall Mounting Detail	6
Dispersion Method	7
Hose Kit Installation	8
Steam Piping Examples	9
Piping	10
Blower Pack	11-12
Start-Up Procedure	13
Maintenance Instructions & Wiring Notes	14
Trouble Shooting	15
Tool Requirements & Maintenance Notes	16
Exploded Parts Drawing	17
Parts List	18

Internal Features of the PURE Humidifier Co. "ECDDR" Series Electric Humidifier

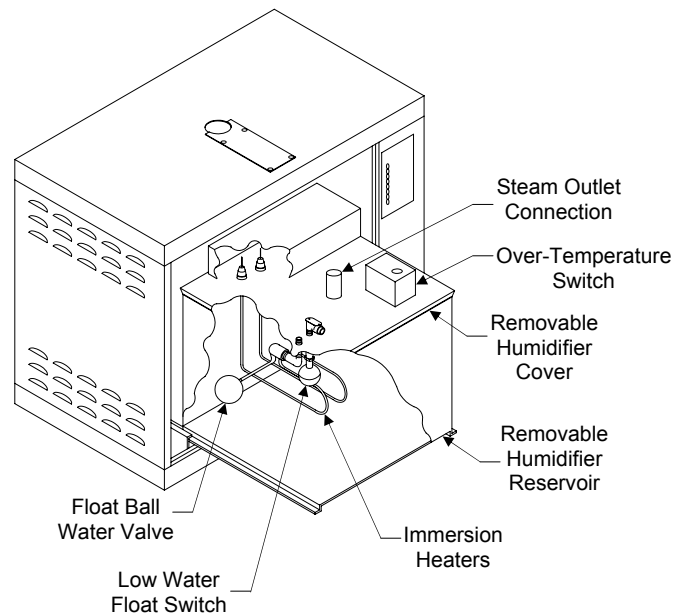



Capacity & Weights Electrical Specifications

Capacity & Weights “ECDDR” Series

Deionized Water Unit Model No.	Steam Output Capacity †		Humidifier Weight			
	Lbs/hr	Kg/hr	Empty		Full	
			Lbs	Kg	Lbs	Kg
ECDDR-5	15.0	6.8	139.0	63.1	223.0	101.2
ECDDR-10	30.0	13.6	140.0	63.5	224.0	101.6
ECDDR-15	45.0	20.4	141.0	64.0	225.0	102.1
ECDDR-20	60.0	27.2	142.0	64.4	226.0	102.5
ECDDR-25	75.0	34.0	143.0	64.9	227.0	103.0
ECDDR-35	102.0	46.3	146.0	66.2	230.0	104.3

Electrical Specification “ECDDR” Series

Deionized Water Unit Model No.	KW	No. of Heaters	Single Phase Amperage					Three Phase Amperage				Control Circuit Voltage	
			120V	208V	240V	480V	600V	No. of Heaters	208V	240V	480V		600V
ECDDR-5	5	Single	41.7	24.0	20.8	10.4	8.3	Triple	13.9	12.0	6.0	4.8	24 vac
ECDDR-10	10	Double			41.7	20.8	16.7	Triple	27.8	24.1	12.0	9.6	24 vac
ECDDR-15	15	Triple				31.3	25.0	Triple	41.7	36.1	18.1	14.4	24 vac
ECDDR-20	20	Triple				41.7	33.3	Triple		24.1	19.2		24 vac
ECDDR-25	25	Triple				41.7		Triple		30.1	24.1		24 vac
ECDDR-35	34	Triple						Triple		40.9	32.7		24 vac

† The above capacities are based on 100% efficiency. Actual humidifier capacity may vary due to the heat loss from the humidifier reservoir. The ambient air temperature, air velocity, and injection tube system will affect the rate of heat loss from the humidifier reservoir.

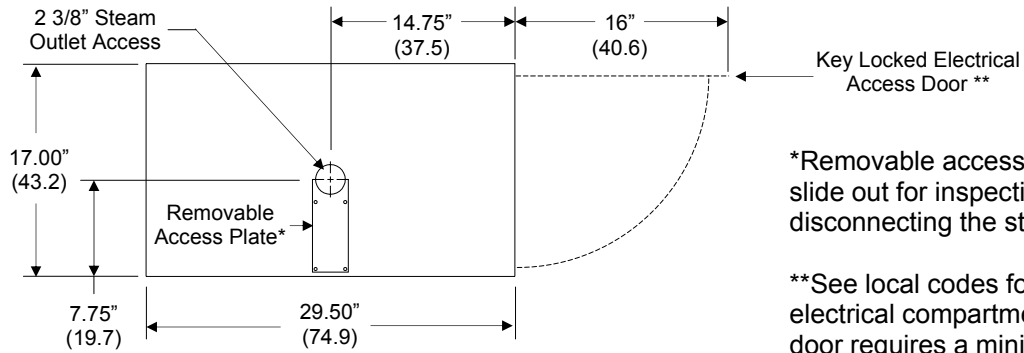

TOP VIEW

*Removable access plate allows reservoir to slide out for inspection and cleaning without disconnecting the steam supply piping.

**See local codes for minimum clearance to electrical compartment. The electrical access door requires a minimum clearance of 16" to fully open.

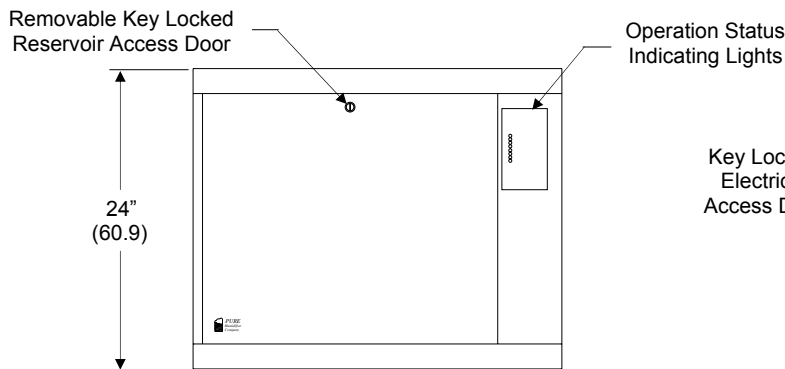

FRONT VIEW

RIGHT SIDE VIEW

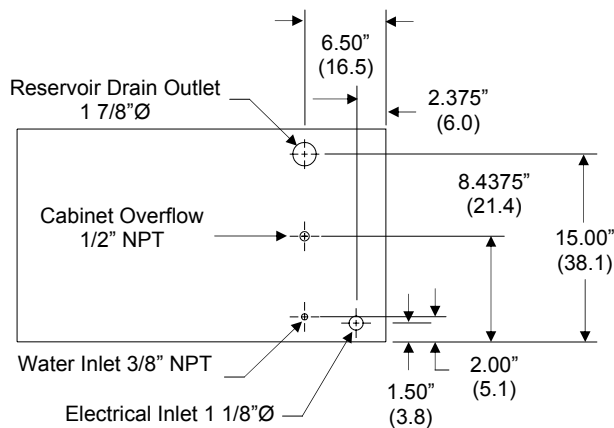

BOTTOM VIEW

Note: Dimensions are typical for all ECDDR models.

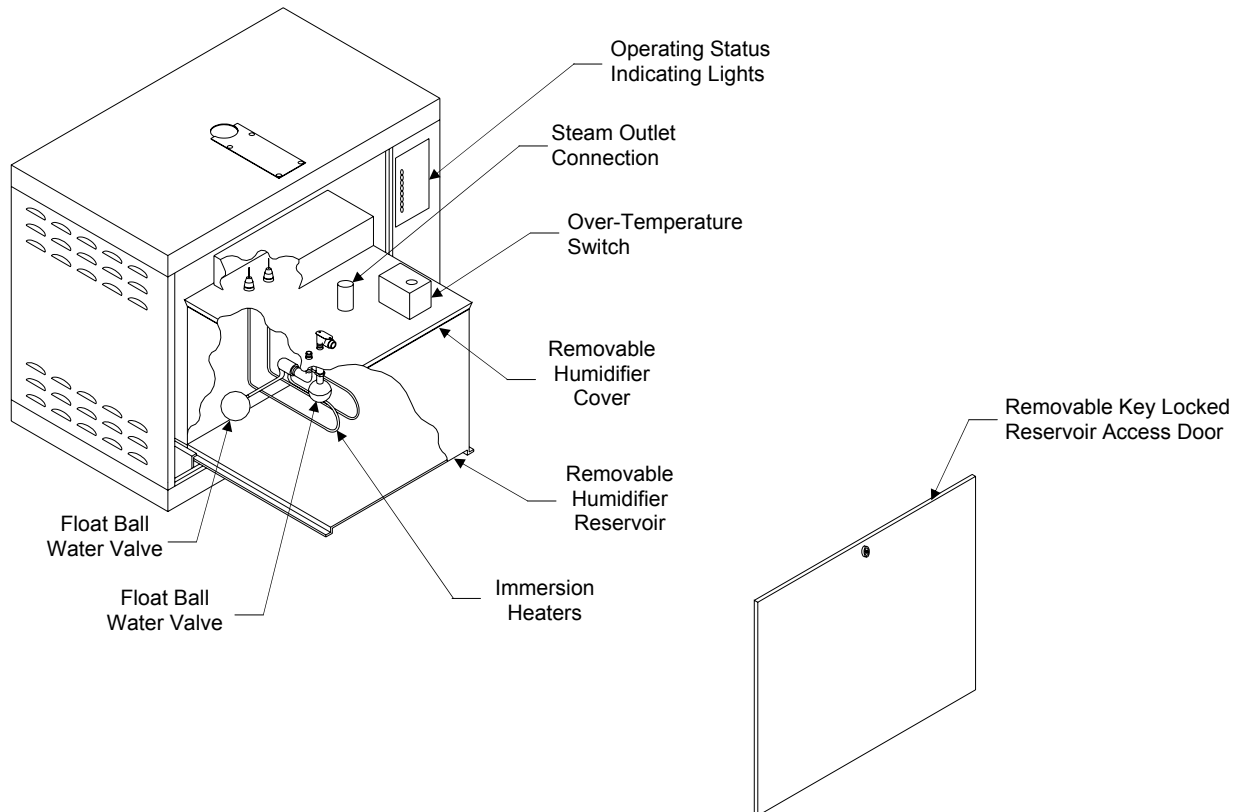

Humidifier Features

- On/Off, Time Cycle Modulation* or SCR* control
- Visible status and diagnostic LED indicator lights
- Stainless steel float type water make-up valve
- Low water cut-off float switch
- High efficiency incoloy immersion water heaters
- 18 gauge steel cabinet with baked enamel paint finish
- Internal stainless steel evaporating reservoir mounted on slides for easy removal
- Key locked doors for both reservoir and electrical access
- Easy and simple installation options
- Dispersion methods include Insty-Pac*, Fast-Pac* hose kit*, or blower pack assembly* for room distribution
- Manual reset over-temperature safety switch
- INTAC® microprocessor control system*

* Optional features



Location & Mounting

Location

The location selected must provide for electrical service, cold or hot water supply, and sanitary drain.

When selecting a location, try to keep the humidifier within 10 feet (305 cm) of the duct to avoid unnecessary heat losses and condensation within the steam supply line.

Visible “fog” will saturate and condense when it contacts objects such as turning vanes, filters, fans, elbows, or take-offs. The warmer the air, the more easily it will dissipate the visible steam. The most active and warmest portion of the duct will provide better mixing of the steam and air. The injection tube should be mounted a minimum of 2 feet (61 cm) downstream from an elbow or other turbulent air flow area.

Avoid mounting the injection tube closer than 8-10 feet (244-305 cm) upstream of objects that could become saturated and condense the steam (reference paragraph above). If the duct layout does not provide a straight, unobstructed run of 8-10 feet (244-305 cm), a multiple injection tube system should be considered to reduce the visible steam travel distance.

Location of Controls

It is important to avoid mounting any controls within the visible steam. The controls should be mounted a minimum of 8-10 feet (244-305 cm) downstream from the humidifier injection tube. Due to the temperature rise that exists within the visible steam dissipation area, thermostats should not be mounted near the injection tube. High-limit humidistats should be installed before any duct obstruction to make sure the humidifier is interrupted before saturation can occur on the object. The high-limit should be mounted a minimum of 8-10 feet (244-305 cm) downstream from the injection tube.

Mounting

Mounted from the wall. The humidifier should be mounted dead level in both directions. PURE Humidifier Co. supplies the wall mounting bracket. Bracket is mounted to wall studs first. The bracket must be mounted to wall studs or additional support must be provided in the field. ECDDR cabinet is then hung on the slip fit bracket.

Drain Pan Mounting

A drain pan is an additional safety feature which would be required to be supplied in the field. In a proper humidifier installation a drain pan is not required. However, if the injection tube or tank is located in an area that contains valuable equipment or is a water sensitive area, PURE Humidifier Co. recommends the addition of a drain pan under the injection tube or tank. The drain pan should extend a minimum of 3 feet (91 cm) downstream from the injection tube. The pan should be a size which is sufficient to retain sudden drainage of the contents of the humidifier. The pan should be drained to a sanitary drain.

Injection Tube Installation

Single tube units should have the injection tube installed in the center of the duct. Multiple tube units should have the tubes staggered within the duct (see multiple hose kit installation).

Injection tube should be pitched 2 inches (5 cm) per foot (31 cm), back to the humidifier. If proper pitch cannot be maintained, or the injection tube is mounted lower than the humidifier, a drain “tee” will be required.

Install the tube with the steam ports injection steam up. NOTE: If narrow ducts (6”/15 cm or less, in height) are utilized, install the tube with the steam ports injecting with the air flow slightly (2 o'clock position).

Galvanized steel duct plates are provided to seal the opening where the tube enters the duct.

Multiple Injection Tube Assemblies

See page 9 for details.



PURE
Humidifier

Wall Mounting Detail

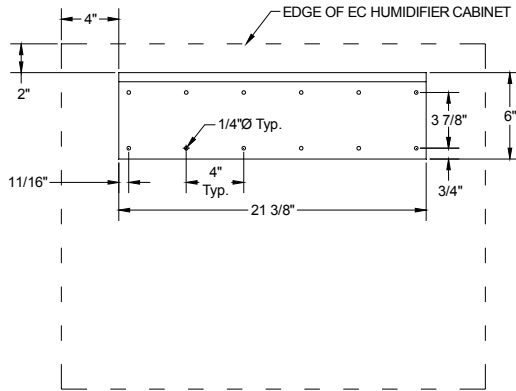

HANGER BRACKET HOLE DETAIL
FRONT VIEW

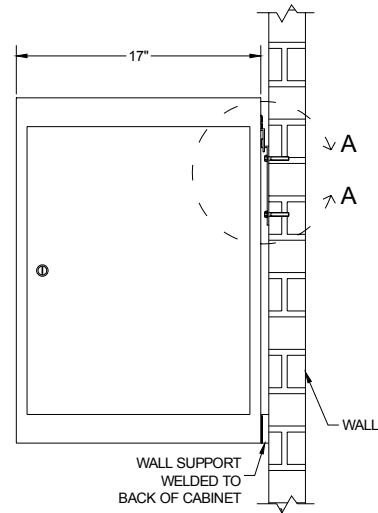

RIGHT SIDE VIEW

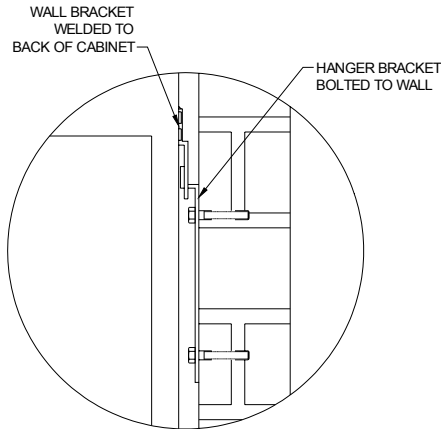

DETAIL
A - A

Mounting

Mounted on the wall. The humidifier should be mounted dead level in both directions. PURE Humidifier Co. supplies a wall mounting bracket. Bracket is mounted to wall studs first. The bracket must be mounted to wall studs or additional support must be provided in the field. ECDDR Cabinet is then hung on slip fit bracket.

The humidifier should be mounted dead level in both directions. PURE Humidifier Co. supplies a wall mounting bracket. Bracket is mounted to wall studs first. The bracket must be mounted to wall studs or additional support must be provided in the field. ECDDR cabinet is then hung on slip fit bracket.

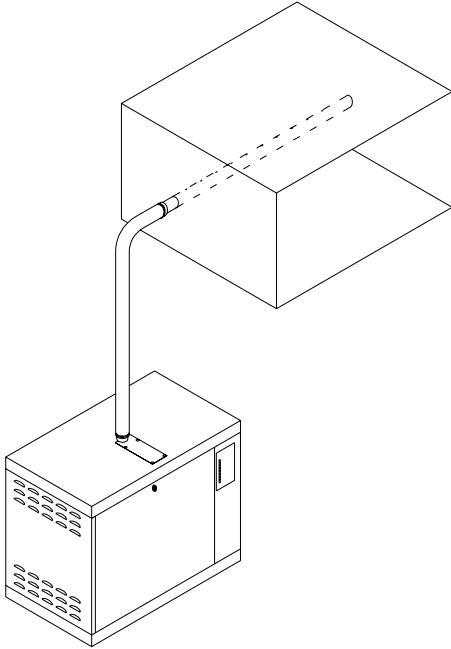

Flexible Hose Kit

Allows remote mounting of the humidifier reservoir from the duct. Also allows the humidifier to be located below a wall mounted duct.

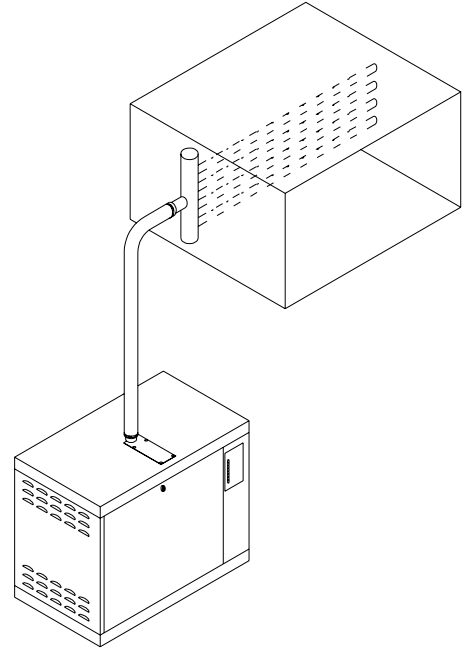

**Insty-Pac and Fast-Pac
Multiple Injection Tube Assemblies**

For applications where you need a short dissipation distance. Allows remote mounting of the humidifier reservoir from the duct. Also allows the humidifier to be located below a wall mounted duct.

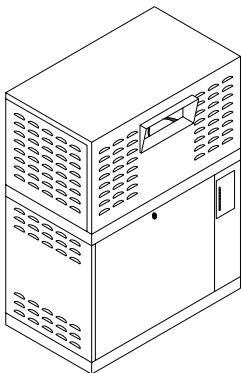

Blower Pack for Direct Room Humidification

Allows humidifier to be mounted directly on the wall within the space to be humidified.

Flexible Hose Kit Installation

Hose kits should have the injection tube installed in the center of the duct. Hose and injection tube should be pitched back to the humidifier two inches (5 cm) per foot (31 cm). If proper pitch cannot be maintained, or the injection tube is mounted lower than the humidifier, a drain "tee" will be required (reference drain "tee" illustration).

Install the tube with the steam ports injecting steam up. NOTE: If narrow ducts (6"/15 cm or less, in height) are utilized, install the tube with the steam ports injecting slightly with the air flow (2 o'clock position).

The hose connects to the injection tube and humidifier with stainless steel hose clamps (by PURE Humidifier Co.).

Galvanized steel duct plates are provided to seal the opening where the tube enters the duct.

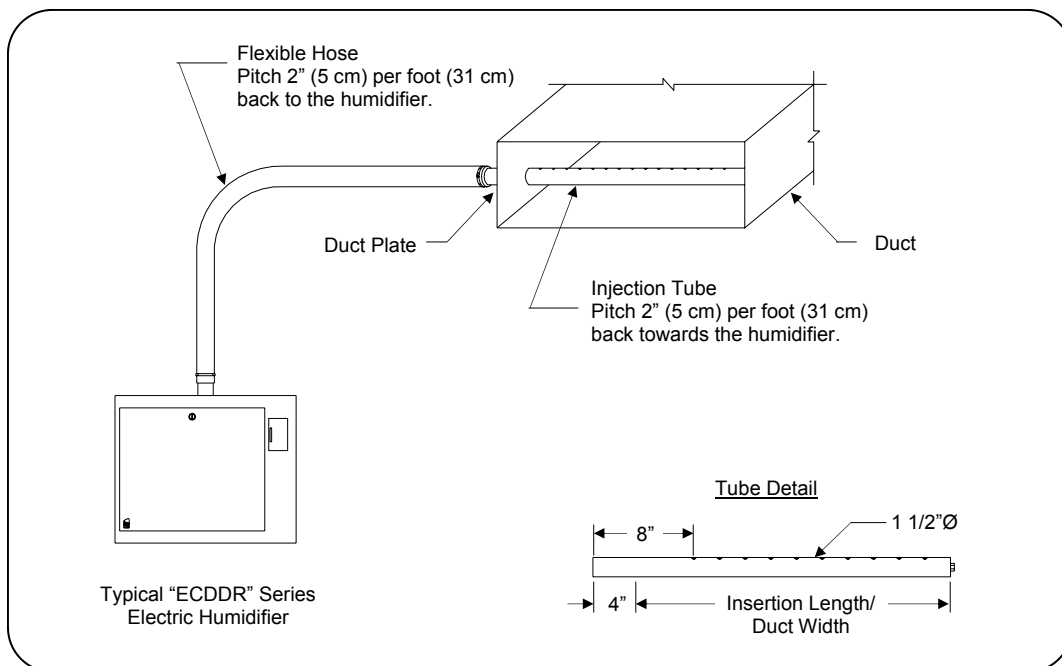
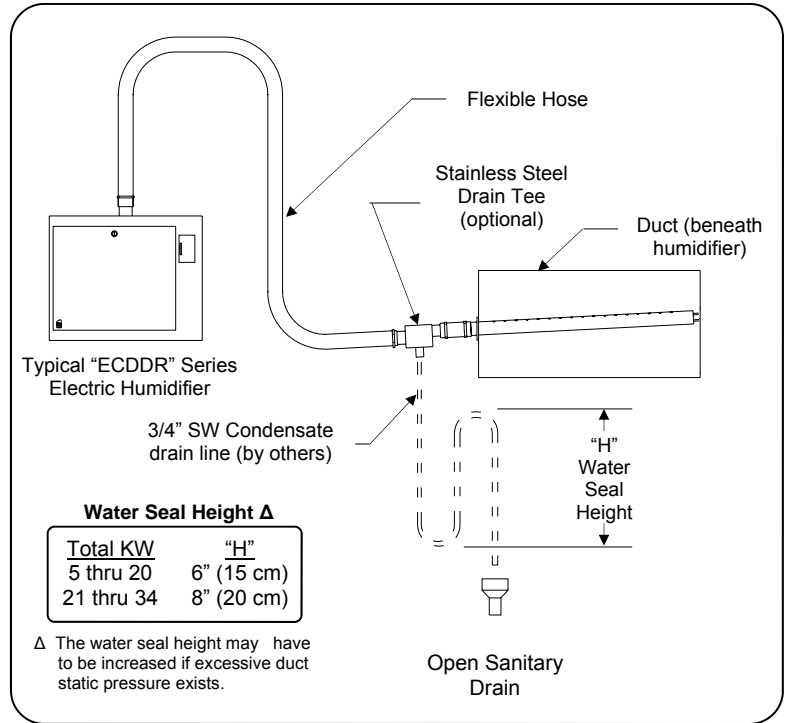

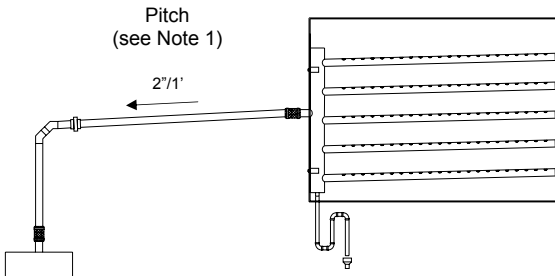

Pitched Towards Steam Generator

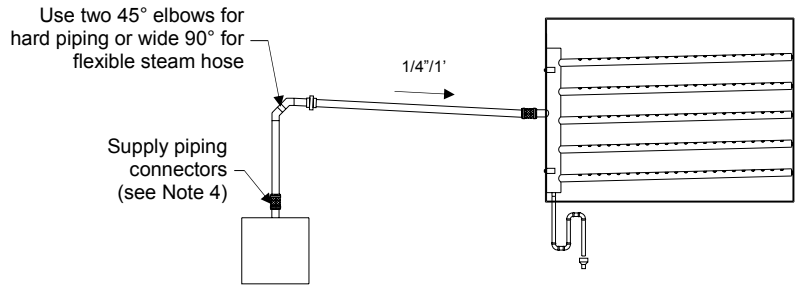

Pitched Towards Tube Assembly

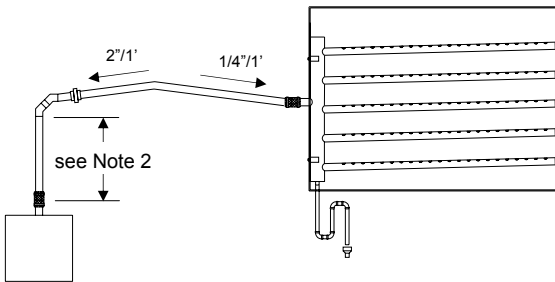

Pitched Towards Steam Generator and Tube Assembly

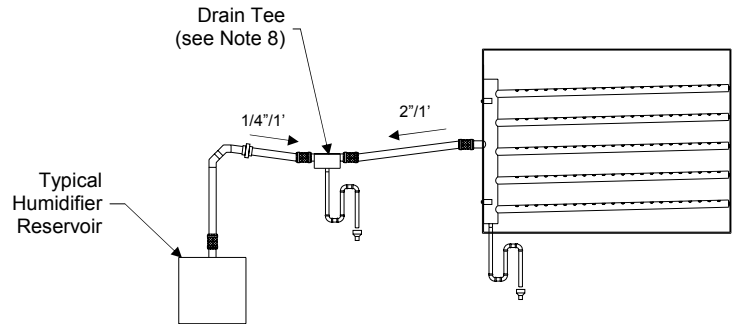

Pitched Towards Drain Tee

Notes:

1. Pitch hard piping or flexible hose 2" per foot if steam is flowing uphill, 1/4" per foot if the steam is flowing downhill. Reference piping examples shown.
2. When feasible to do so, install a minimum one-foot riser from the top of the tank to reduce condensate carry over.
3. Install union to allow for cover removal.
4. Use flex connectors or unions to allow for easy removal of cover.
5. Support flexible hose every 18" to avoid sagging.
6. Hard piping or flexible hose must match reservoir outlet size. Do not use supply piping with a smaller inside diameter than the reservoir outlet.
7. Failure to follow the piping recommendation on this page may result in blown water seals, leaking cover gasket or dispersion tubes spitting.
8. Install a Drain Tee at any low spots in supply piping run where condensate will accumulate.
9. Reference job specific tube assembly O&M included with your order for complete details.

Water Supply Piping

This style humidifier utilizes a float operated fill valve system which is designed for use with deionized, demineralized, or reverse osmosis water. Use of mineralized tap water will cause fill valve failure and will void the humidifier warranty.

Cold or hot deionized, demineralized, or reverse osmosis water can be supplied to the humidifier. A minimum water pressure of 15 psi (1.03 Bar) should be maintained to provide the proper water level within the humidifier. If the water pressure is above 50 psi (3.5 Bar), water hammer could occur and a pressure reducing valve or shock arrester should be used. The humidifier has a factory built-in 1.5" (4 cm) air gap between the water inlet and the overflow. Local codes should be checked to see if the addition of a vacuum breaking device is required. Water connection is made at the bottom of the humidifier with 3/8" NPT piping.

Drain Piping

The "ECDDR" style humidifier requires one 3/4" stainless steel drain piping connections run to an open drain.

The drain piping should be stainless steel. The use of PVC piping is not recommended; the humidifier water temperature may cause the PVC to soften and fail.

The "ECDDR" humidifier has a factory piped internal water seal. **The humidifier reservoir must be manually overfilled to prime the water seal prior to operation.**

If gravity drain is not possible please use a condensate pump rated for 212°F water or PURE Humidifier Co. Part No. 16033 Hartell A3X-115 condensate pump.

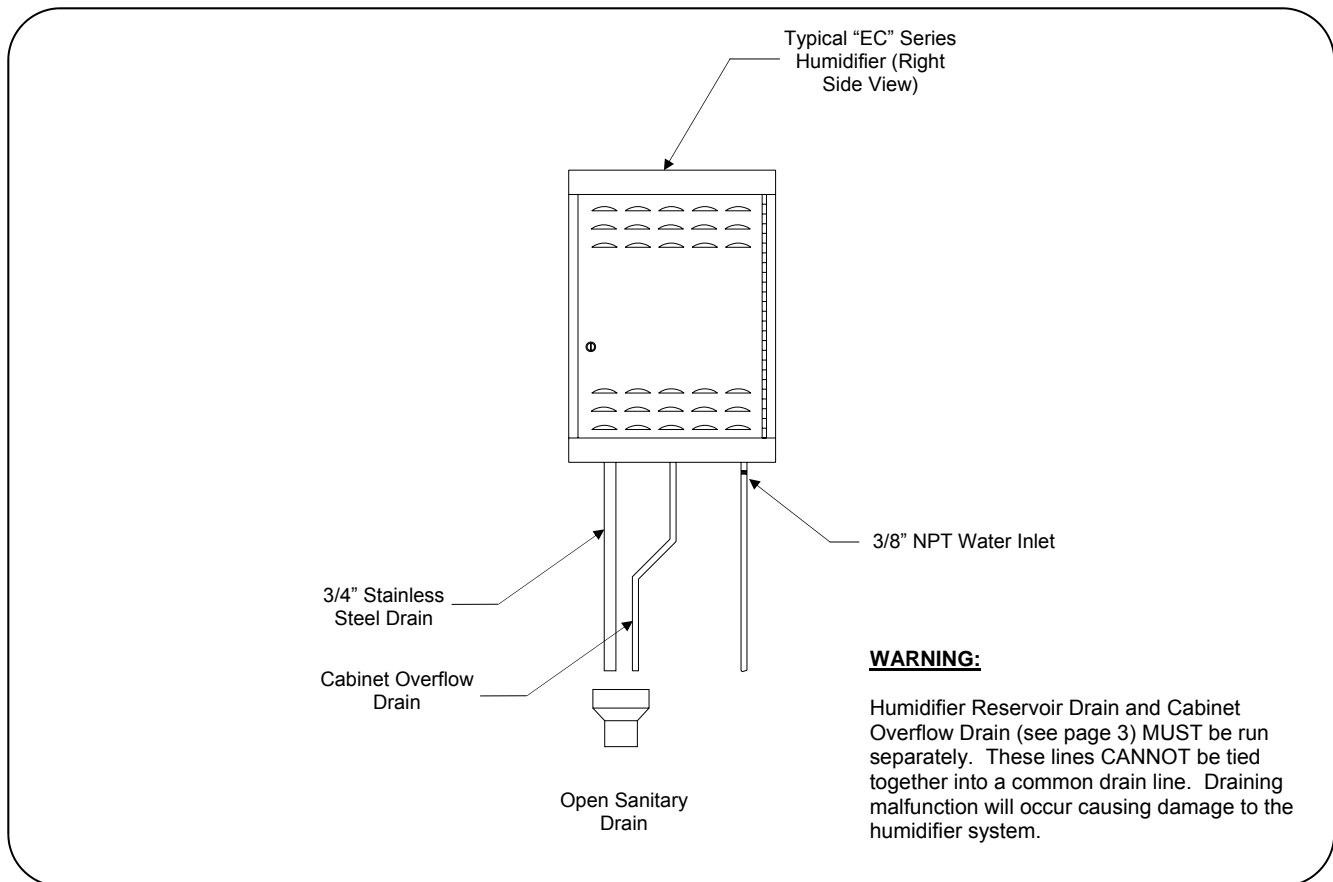

Optional Blower Pack

In applications where a ducted air system is not available, PURE offers the optional Blower Pack. The Blower Pack contains a two-speed adjustable blower that moves the air over the steam discharge outlet and disperses the steam directly into the space (see Fig. 1). The Blower Pack mounts directly on top of the “ECDDR” humidifier or can be remote mounted (see Fig. 2).

Locating Blower Pack

The distance that visible steam will travel after leaving the Blower Pack is dependent upon the relative humidity in the room and the capacity of the humidifier. If this visible steam comes in contact with any solid object (walls, beams, machinery, etc.), it may form condensate and drip. Refer to Fig. 3 and Table 4 (Table 4 is located on page 12) for data on visible steam travel. This will aid you in planning the location of the Blower Pack.

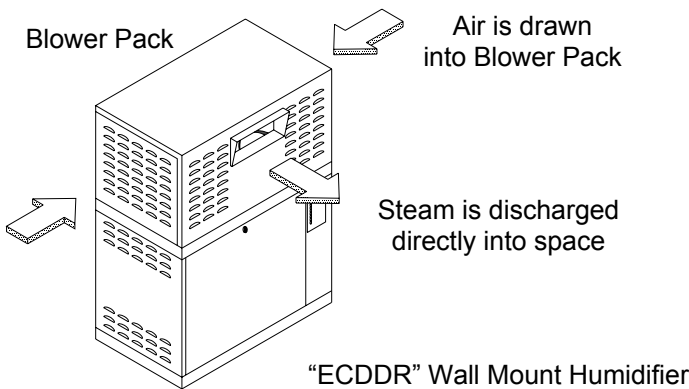

Remote Mounting

The Blower Pack may be remote-mounted up to ten feet away from the “ECDDR” wall mount humidifier (see Fig. 2).

“ECDDR” With Optional Blower Pack
Fig. 1

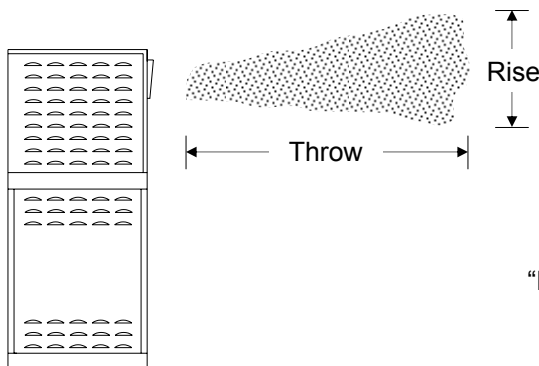

Visible Rise and Throw
Fig. 3

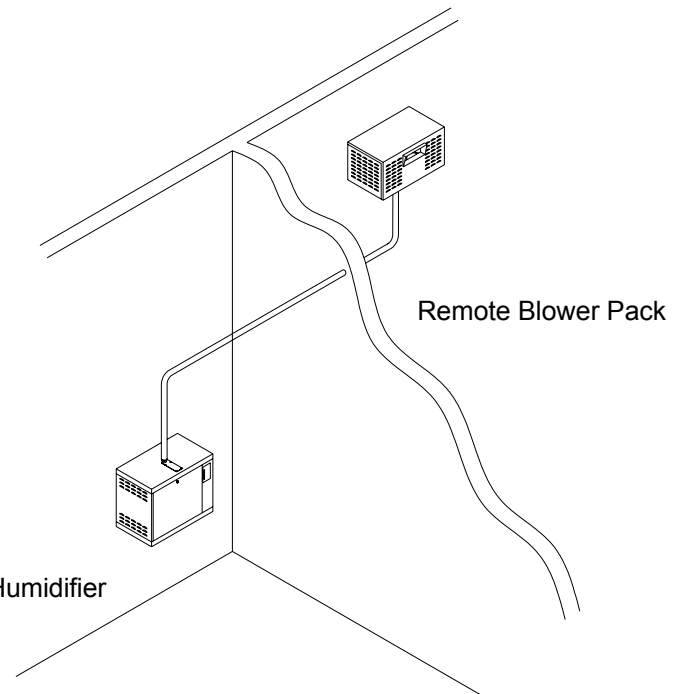

Remote Mounted Blower Pack
Fig. 2



Blower Pack

Locating Blower Pack

The distance that visible steam will travel after leaving the Blower Pack is dependent upon the relative humidity in the room and the capacity of the humidifier. If this visible steam comes in contact with any solid object (walls, beams, machinery, etc.) it may form condensate and drip. Refer to Fig. 3 (Fig. 3 is located on page 11) and Table 4 for data on visible steam travel, this will aid you in planning the location of the Blower Pack.

Visible Steam Rise & Throw		Humidifier Model					
		ECDDR-5	ECDDR-10	ECDDR-15	ECDDR-20	ECDDR-25	ECDDR-35
50% RH	Rise (ft)	1'	2'	3'	4'	5.5'	8'
	Throw (ft)	8'	10'	13'	16'	18'	23'
60% RH	Rise (ft)	2'	3'	4'	5'	6'	8'
	Throw (ft)	13'	14'	16'	18'	20'	25'

Throw is the horizontal distance the visible steam travels from the steam discharge.
Rise is the vertical distance the visible steam travels from the steam discharge.
 Objects in the direct line of the visible steam or objects that are cooler than the ambient temperature may accumulate condensation.
Note: Data above based on 70°F room temperature.

Table 4

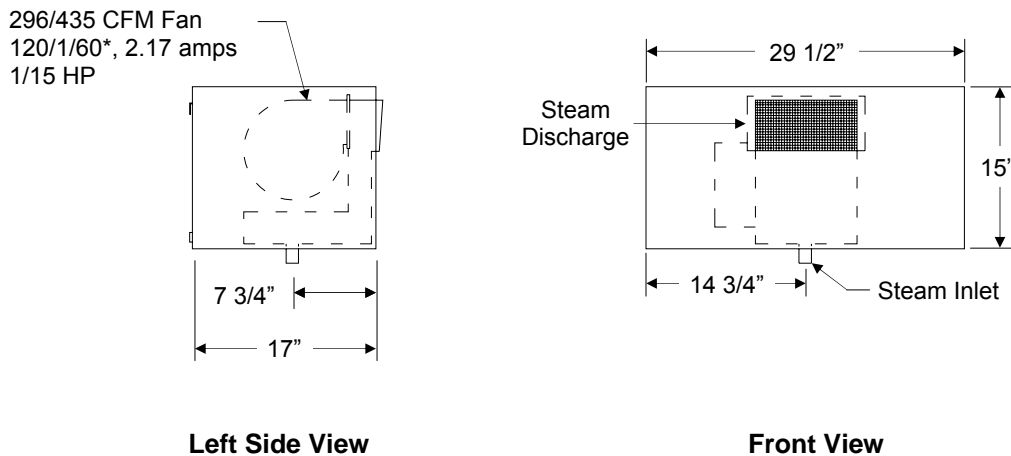

Optional Blower Pack Dimensions

Fig. 5

Blower Pack weight is 60 lbs (27.2 kg)

* Blower requires a separate 120/1 circuit (by others)



Start-Up Procedure

Introduction

Before starting the “ECDDR” PURE Humidifier Co. Electric Humidifier, check the following installation procedures:

1. MOUNTING – Verify that the humidifier evaporating chamber is securely supported and that the evaporating chamber is level in both directions.
2. INJECTION TUBE - Verify that the humidifier injection tube is mounted within the duct with the proper pitch back to the humidifier (2”/5 cm per foot/31 cm). NOTE: If the humidifier evaporating chamber or the flexible hose (optional) is mounted higher than the injection tube, a drain “tee” is required to drain the condensate out of the injection tube and steam line.
3. ELECTRICAL - Verify that all wiring connections have been connected in accordance with the wiring diagram. **CAUTION: Live power may exist in the control cabinet. Turn off the main power at the disconnect switch before verifying the electrical connections!**
4. PIPING - Verify that all piping connections have been completed as recommended and that water pressure is available to the humidifier.
5. Verify that the plastic bubble wrap installed for shipping purposes has been removed from the internal float ball assembly.
4. Turn the electric power “on” to the humidifier. The “Power” LED light on the controller should be illuminated.
5. Set the switch on the control board to the “Normal” position.
6. Open the water supply valve (by others) and allow the humidifier evaporating chamber to fill to the proper level.
7. After the humidifier is full of water, the “Water Level Full” LED will illuminate. Turn humidistat up to call for humidifier demand.
8. Verify the low water safety circuit by opening the manual drain valve. As the humidifier tank is draining, the “Water Level Full” light should go out when the low water level is reached; this indicates that the low water safety circuit is operational.
9. Close the drain valve and allow the humidifier to fill to the proper level.
10. Make sure all the optional safety switches are satisfied (airflow proving switch, high-limit humidistat, etc.).
11. The heater(s) should energize on a call from the humidistat.

Start Up Procedure

1. With the power “off”, set the switch on the control board to the “Stand-by” position (the control board is located within the humidifier control panel door).
2. Close the humidifier manual ball valve (located inside the humidifier evaporating chamber compartment).
3. Turn the controlling humidistat to the lowest setting (no call for humidity).
12. Check operation of optional field-installed safety switches (airflow proving switch, high-limit humidistat, etc.) to make sure that they turn the power off to the control circuit. The safety switches should shut-off the humidifier heaters whenever one or more of the optional safety switches create an “open circuit”.
13. Check heater amperage draw by testing and recording voltage and amperage in each phase. Readings should match the factory heater nameplate.
14. Allow the humidifier to come to a full boil, this will take approximately 15 minutes.
15. Carefully check cover and all connections for any leaks while humidifier is boiling. Any leaks should be sealed.



Maintenance Instructions & Wiring Notes

PURE Humidifier Co. “ECDDR” Maintenance Instructions

The “ECDDR” Series Electric Humidifier is practically maintenance free. However, the humidifier should be inspected and placed on a dedicated maintenance schedule to ensure continued operation of the humidifier and its accessories.

<u>Inspect/Maintenance Item</u>	<u>Procedure to Follow</u>
Water make-up float valve	Check to make sure the fill valve is operating properly. If the valve appears to continually fill, check the valve adjustment or valve seat and seal (see trouble shooting instructions).
Low water float switch	Check to make sure the switch will shut the humidifier off when the water level drops too low. Open the drain valve to allow water to drain out for checking purposes. Make sure to reset the drain valve after inspection is completed.
Safety interlocks (air flow, high-limit)	Check to make sure the safety interlocks (air flow, high-limit, etc.) will shut down the humidifier.
Immersion heaters	Verify the correct amperage is being drawn by the heating element. Reference the wiring diagram for correct amperage.
Humidifier cover/tank	Inspect for any leaks. Repair as required. Remove the heater assembly and remove mineral deposits from floor of the humidifier reservoir. If excessive mineral build-up is found, the cover may need to be removed to facilitate complete cleaning of the humidifier.
Flexible hose	Inspect for cracks or leaks. It is normal for the hose to become hard and develop a “set”.

Wiring Notes

1. Main power disconnect is by others.
2. Humidifier to control panel wiring diagram is provided within the humidifier control panel door. All field wiring connections are shown on the wiring diagram.
3. All wiring to be per local and national electrical codes.
4. Humidifier is ETL Testing Laboratories tested and approved.
5. **All control circuit wiring should be ran within separate conduit from the main power wiring.**
6. If optional modulating control is used, modulating humidistat wiring must be ran within separate conduit from the main power.



PURE
Humidifier

Trouble Shooting

<u>Problem</u>	<u>Possible Cause</u>	<u>Recommended Action</u>
Humidifier will not heat	Blown heater fuse(s)	Check and replace.
	Control transformer not producing 24 vac control voltage	Check transformer output and verify voltage.
	Safety controls open (air flow switch, high-limit, etc.)	Verify that all safety controls are completing the safety circuit.
	Faulty humidity sensor	Verify voltage to and from humidity sensor.
	Faulty immersion heater	Check and verify heater voltage and amperage. Compare to diagram or nameplate label ratings.
Humidifier will not fill	No water pressure	Check water supply.
	Drain valve open	Close drain ball valve.
	No power to the fill valve	Check float valve seat for dirt.
Humidifier will not stop filling or is short cycling	Fill valve stuck open	Check float valve seat for dirt. Adjust float ball arm.
	Drain valve open	Close drain ball valve.

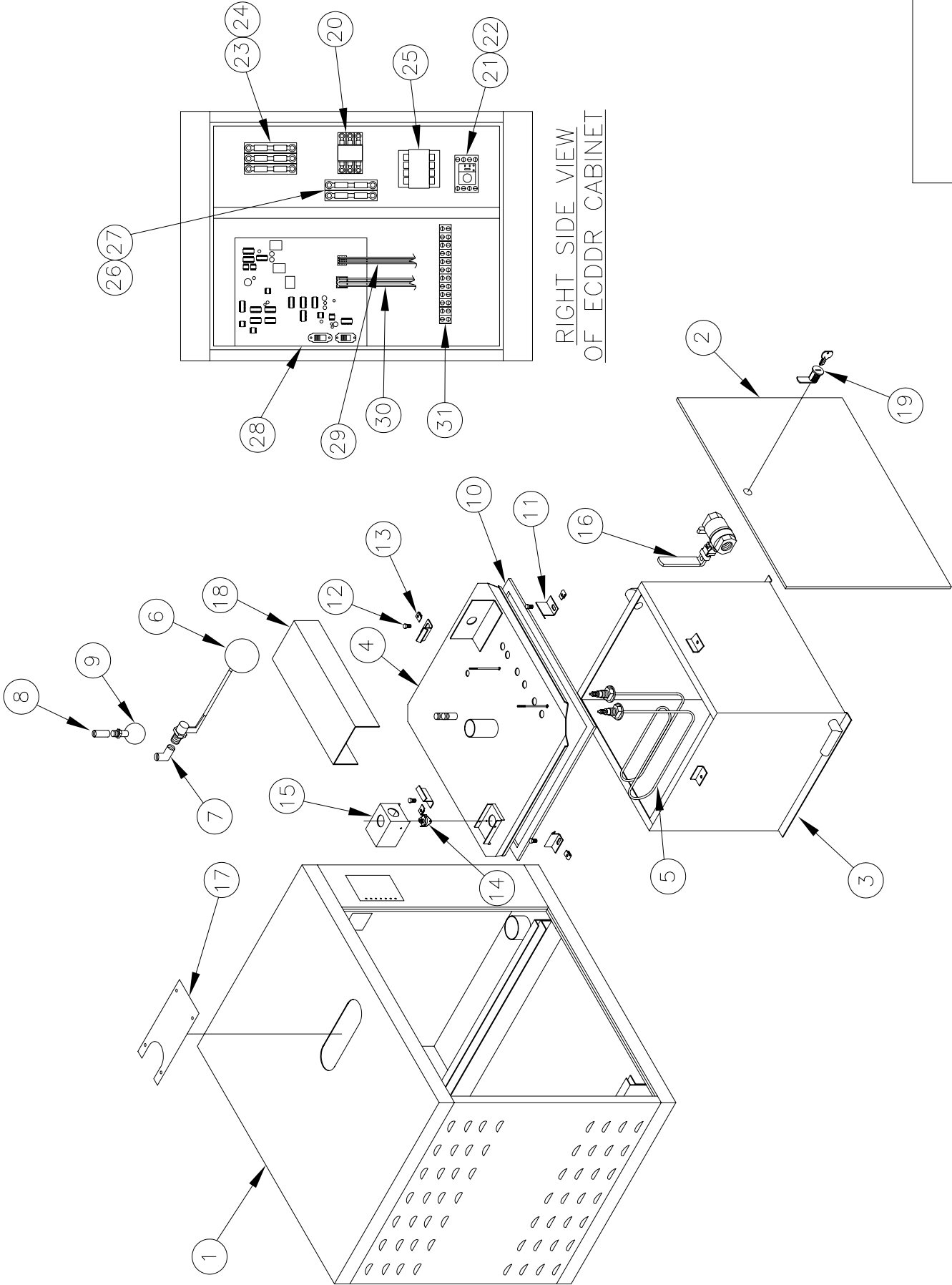

RIGHT SIDE VIEW
OF ECDDR CABINET

Title: ECDDR ASSEMBLY		Dwg No: 1588	
Scale: No Scale	Date: Apr. 12, 2005	Drwn: P.R.G.	

**Pure Humidifier Company "ECDDR" Series
Parts List & Two Year Recommended Spare Parts**

Item No.	Description	Part No.	Qty Per Unit.	Rec. SpareQty.
1	ECDDR Exterior Cabinet	18001	1	
2	ECDDR Cabinet Door, no lock, see item 19	18002	1	
3	ECDDR Reservoir Assembly	A	1	
4	ECDDR Reservoir Cover Assembly	A	1	
5	Immersion Heating Elements	A	A	
6	Float Valve & Ball, 316 SST	09079	1	
7	1/4" 90 Degree Elbow, 316 SST	07019	1	
8	304 SST Half Coupling	07098	1	
9	Low Water Float Switch	15048	1	
10	Cover Gasket	A	A	
11	Cover Clamp	15930	A	
12	Cover Clamp Screws	15522	A	
13	10-24 U-Nut	15524	A	
14	Overtemp Protection Switch	15047	1	
15	Overtemp Switch Housing	15072	1	
16	1/2" Ball Valve, 316 SST	09089	1	
17	Cabinet Cover Plate	18005	1	
18	Power Supply Cover	18008	1	
19	Door Lock and Keys	12001	1	
20	Heater Contactor	A	1	
21	Pilot Relay	12022	1	
22	Relay Socket	12020	1	
23	Fuse Block	A	1	
24	Heater Fuses	A	3	
25	Step-Down Transformer	A	1	
26	Fuse Holder	A	1	
27	Fuses	A	2	
28	Control Board	A	1	
29	Wiring Harness	A	A	
30	Wiring Harness	18027	1	
31	14 Point Terminal Strip	12044	1	

NOTES/CODES:

A = Part Number and quantity vary with model number.

When ordering replacement or spare parts, please have the following information available: Model Number, Primary Volage, Serial Number, No. of Heaters & Heater KW and any options (ie, automatic drain, modulating control or insulation etc.)



141 Jonathan Blvd. North
Chaska, MN 55318
Tel: (952) 368-9335 Fax: (952) 368-9338
www.purehumidifier.com