

## **MODEL SF-5 and SW-5**

### **GENERAL INFORMATION:**

This space type humidifier is designed to be suspended from the ceiling or mounted on a shelf. Hanging brackets are provided but supports from the ceiling or shelf must be furnished by others.

The humidifier consists of two assemblies; the water reservoir which includes a float type water level valve with 1/8" male pipe thread connection and a safety overflow port and the atomizer assembly which is a delicately balanced, completely self-contained unit that rests in the water reservoir and supports the directional vapor distribution dome.

### **PROCEDURE:**

When selecting exact location for each humidifier be sure that the vapor discharge is approximately six feet from the any obstruction such as lights, pipes or beams. Vapor must also avoid touching humidifier wiring and supports. The following procedure is recommended.

1. Obtain the correct type of vapor distribution dome for each humidifier location.
2. At each location place the correct dome in the reservoir and install one hanging bracket above the water inlet valve, above the position of the water valve on the side of the tank. Then rotate and position the dome so that its vapor ports will avoid this bracket.
3. Place the other hanging brackets in a position which will give level, secure suspension and at the same time will avoid striking the hangers which are to be attached to these brackets.
4. After positioning the reservoir to avoid vapor touching any existing obstructions, locate points on the ceiling directly above the brackets and connect suspension straps or rods at these points. See Figure "B" for further details.

**NOTE:** ALL MINIMUM INSTALLATIONS DIMENSIONS AS SHOWN IN FIGURE "A" MUST BE FOLLOWED.

### **PLUMBING:**

Insert the float valve assembly as illustrated in Figure "C". Run a water supply line near the

ceiling and drop a 1/4" tubing line ( or 1/8" pipe) from the supply line. Keep the drop very close to one of the hangers to avoid creating an obstruction.

Flush all water feed lines before making final connections to avoid clogging the float valve with foreign matter.

Adjust the position of float valve stem to establish a water level in the reservoir about 1/2" below the overflow fitting. See Figure "C" for location of adjusting screw.

Be sure that the water valve arm is directed toward the center of the reservoir when tightening the mounting nut.

### **FOR MODELS WITH FILTER:**

Place the filter in the reservoir with wide flange on top, and the notch directly above marker near water inlet position. Place atomizer assembly into this flange positioned so that the motor extension cord matches the notch in the flange. This avoids the possibility of atomizer legs interfering with the operation of the water regulating valve.

Place vapor dome over the atomizer assembly and run electric cord along one hanger to a female receptacle. Wiring to the receptacle should be through a humidistat control that will operate the humidifier. Refer to Figure "E" for wiring diagram.

Due to a certain amount of "air-washing" when the humidifier is operating, an accumulation of dust and dirt may settle at the bottom of the reservoir. It is therefore recommended that periodic inspection and cleaning be performed as necessary. Also the water drain plug or valve should be opened frequently and the water line flushed out. This periodic maintenance can greatly extend the life of the humidifier.

### **IMPORTANT:**

**IT IS NECESSARY TO KEEP THE RESERVOIR AND ATOMIZER UNIT CLEAN IN ORDER TO MAINTAIN FULL HUMIDIFIER CAPACITY AND NOT OVERLOAD THE MOTOR.**

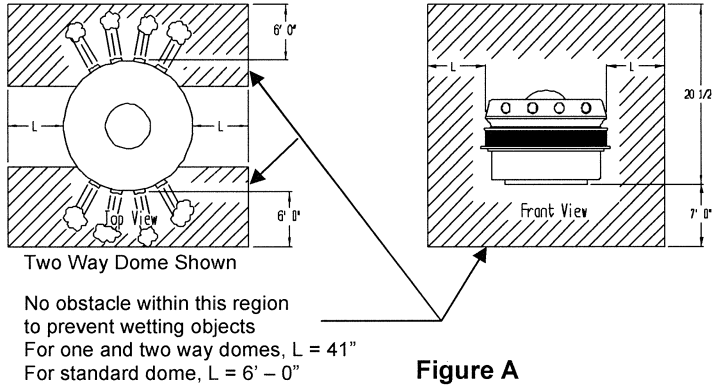
### **MAINTENANCE:**

As stated above, the water reservoir and pump tube must be kept clean and free of minerals, scale and dust. Periodically remove atomizer assembly and clean reservoir with white vinegar. Carefully remove impeller cap (see Figure "D") and clean pump tube with pipe cleaner or test tube brush. Motors have sealed bearings and do not require lubrication.

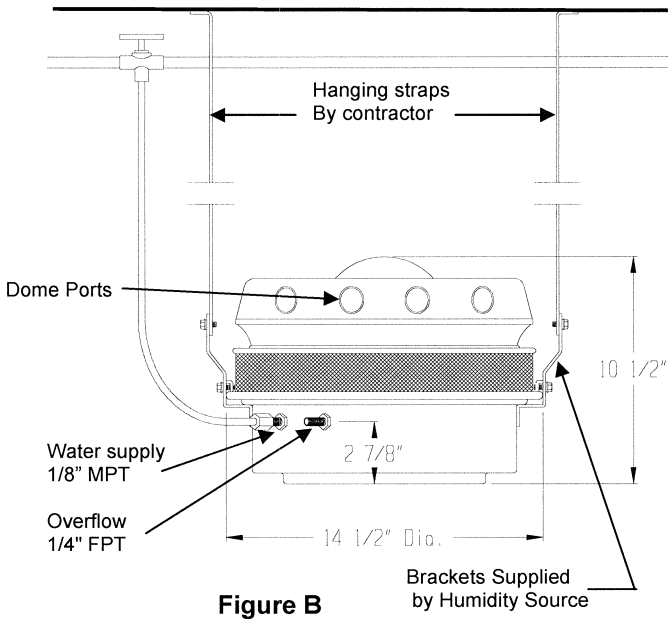
**SERVICE:**

Atomizer motors are sealed in a copper housing at the top of the atomizer assembly. **DO NOT BREAK THIS SEAL.** If for any reason a repair becomes necessary, carefully package the entire atomizer assembly and return intact to your installer, local distributor or Humidity Source, LLC. When ordering parts have model number and voltage available.

**Positive Capacity Atomizing Humidifiers** produce a fine vapor that will quickly evaporate in the air if there is no impingement of water particles against obstructions before absorption is complete. Strict attention to minimum clearance dimensions must be adhered to in order to avoid condensation.

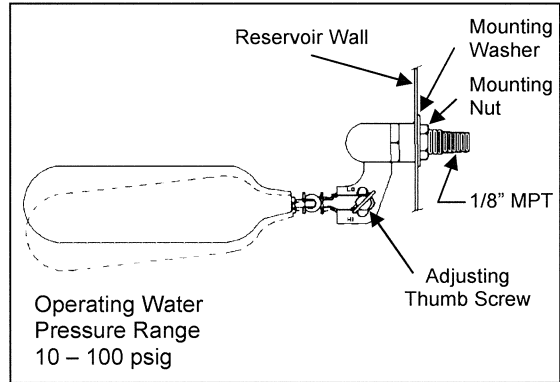


**Figure A**

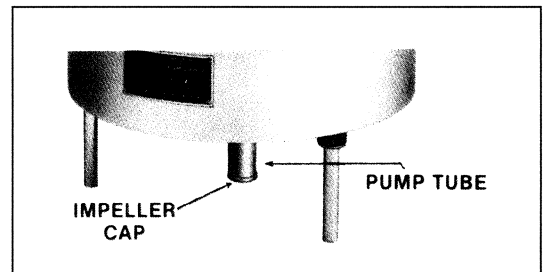


**Figure B**

**FLOAT VALVE**



**Figure C**



**Figure D**

**GENERAL NOTES:**

1. Water reservoir must be level.
2. Keep water supply piping close to hanging strap.
3. Use a humidistat for automatic operation.
4. Use Reverse Osmosis for poor quality water.

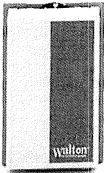


# Humidifier Accessories

---

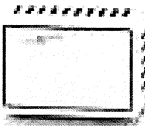
## Humidistats, Sensors & Controls

P-825 Humidistat  
Human Hair Element



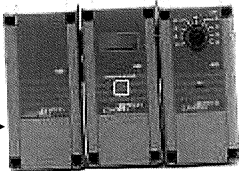
Standard

W351 Humidistat  
Electronic Sensor



For high humidity  
And/or close  
tolerances

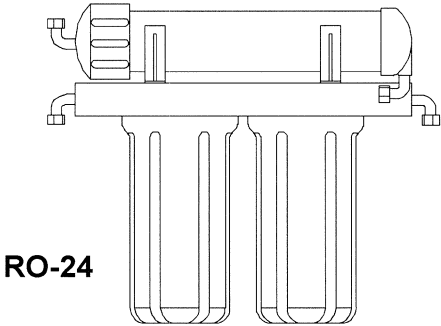
W351 ELECTRONIC HUMIDITY  
CONTROL With Digital Display



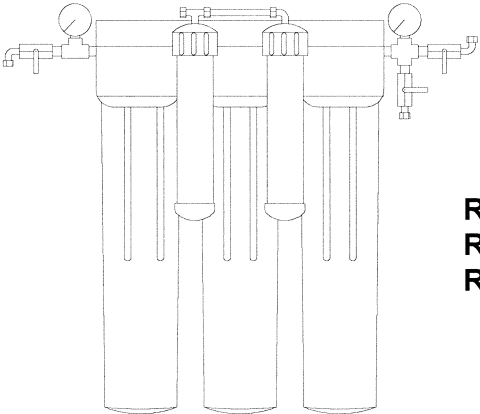
---

## Reverse Osmosis Demineralizers

**Humidity Source Reverse Osmosis**  
water Treatment systems. Sizes range from  
industrial capacities down to individual room units.



RO-24



RO-120  
RO-450  
RO-900

---