

Sample specifications for WF-HP-226

Cold water centrifugal atomizing type humidifier and mounting brackets for installation in duct systems negative or positive pressure. Maximum allowed positive static pressure - .25" H₂O. Water reservoir includes float valve to automatically regulate water level. Humidifier includes motor, impeller, disk and breaker comb to produce a fine vapor. Rotating parts shall be electronically balanced to eliminate vibration. Tubes shall be employed to direct moisture into vertical or horizontal duct systems and equalize humidifier internal air pressure to that of the duct. All water exposed parts to be copper, brass, or non-ferrous alloy. Vapor output of the humidifier shall be constant while in operation and shall not depend on the temperature of the air or water. Humidifier(s) shall be Model WF-HP-226 as manufactured by Humidity source. Must be UL listed for US and Canada.

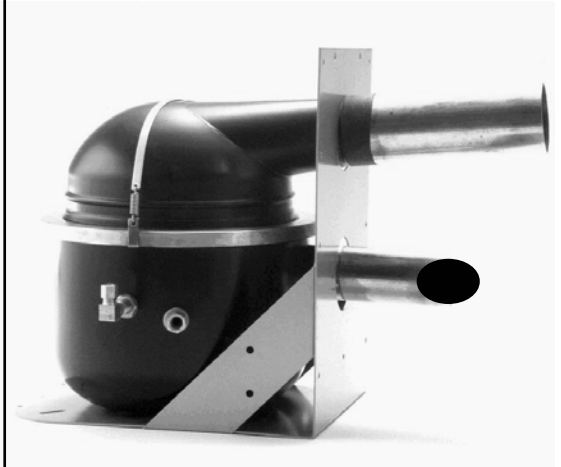

SPECIFICATIONS

CAPACITY

Moisture Output – 3 lb./hr.

WEIGHT

Net: 17 lb.
Shipping: 19 lb.
Operating: 20 lb.

WATER CONNECTIONS & PRESSURES

Supply: 1/8" Male Pipe Thread
Overflow: 1/4" Female Pipe Thread
Operating Pressure Range: 10-100 psig

Electric Motor

50 Watts
115 volts, single phase, 60 Hz.

CARTON SIZE

15 1/2" X 12 1/4" X 15 1/4"

UNIT SIZE

Height: 11 1/2"
Diameter: 10 1/4"

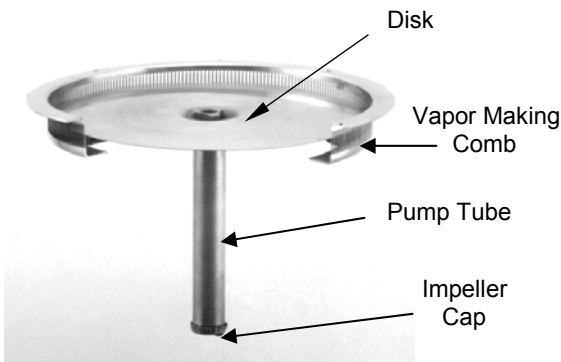

CENTRIFUGAL ATOMIZER

The heart of Humidity Source humidifier units is the patented masterfully engineered Centrifugal Atomizer. Water is drawn by centrifugal force up through the rotating impeller cap and pump tube, then spun across the disk rotating at 3250 RPM striking the Vapor-Maker Comb creating an extremely fine vapor. An integral fan under the rotating disk blows the vapor out of the unit resulting in a fine atomized vapor that is quickly absorbed into the air.

Humidity Source POSITIVE CAPACITY ATOMIZING humidifiers produce moisture that will quickly be absorbed in to the air stream, provided there is no impingement. It is therefore most important that all directions and minimum dimensions be strictly adhered to in order to avoid condensation.

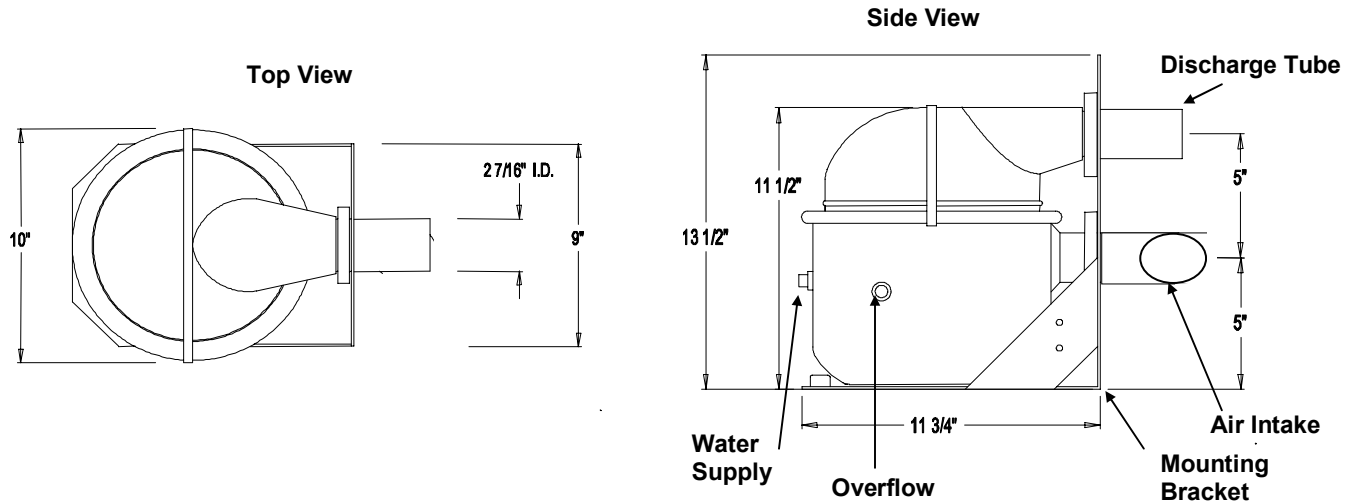

Duct Location Requirements

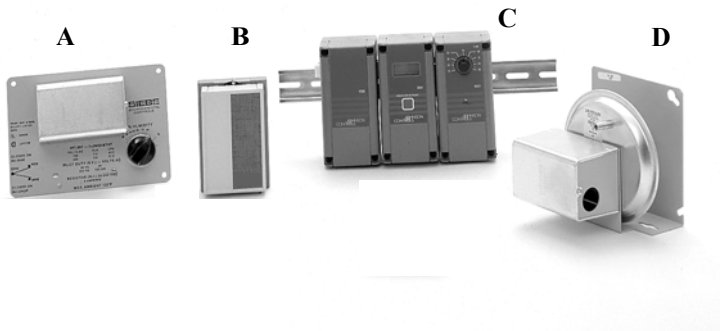
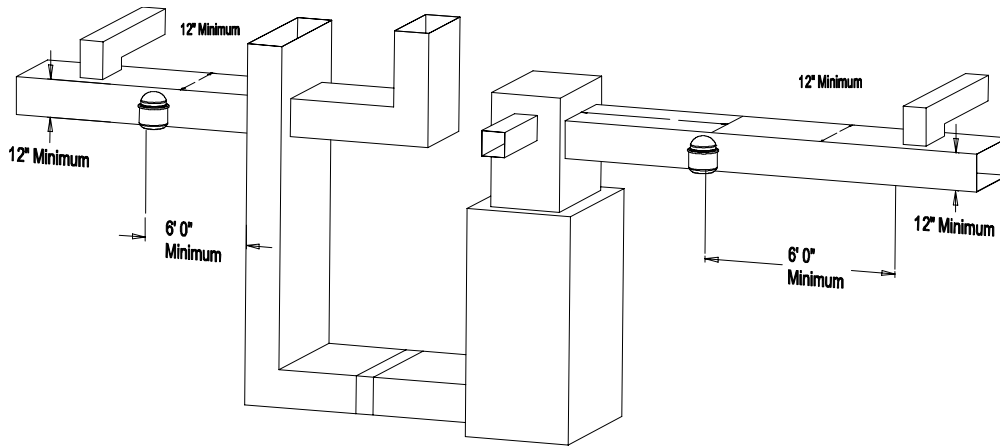

ACCESSORIES

- A. Duct mounted, high limit humidistat. Model No. HC-201
- B. Wall mounted humidistat. Model No. P825.
- C. Johnston Controls electronic humidistat. Model No. W351 with remote sensor (E)
- D. Air duct pressure switch. Model No. PC-301

Humidity Source, LLC

90 Dayton Ave. Suite 58, Passaic, New Jersey 07055
 TEL 973-916-1001 FAX: 973-916-0770