

Sample specifications for WT & WT-B

Cold water centrifugal atomizing type humidifier and mounting plate for installation in bottom of a straight run of air duct that is under either negative or positive pressure. Water reservoir (normally) is suspended from mounting plate to hang below bottom of duct and permit external plumbing connections for feed to automatic water valve within the reservoir. Atomizer and moisture diffusing ring stand in reservoir so that air will pass through, around, and over the atomizer. Atomizer include motor, impeller, disc and breaker comb to produce a fine vapor. Humidifier also includes a rim slide to regulate the air stream entering the atomizing section. All water exposed parts to be copper, brass, non-ferrous alloys and stainless steel. Operation is by means of wall mounted (P825) or return air duct mounted line voltage humidistat. Multiple units may be operated with one humidistat by using relay transformer. See installation instruction.



SPECIFICATIONS

CAPACITY:

Moisture Output – 24lb./hr.

Electric Motor:

Model WT: 1.15 amps, 115 volts, 1 ph – 50/60 hz
Model WT-B: .55 amps, 230 volts 1 ph – 50/60 hz

WEIGHT:

Net: 24 lb.
Shipping: 39 lb.
Operating: 37 lb.

WATER CONNECTIONS & PRESSURES:

Supply: 1/8 in. Male Pipe Thread
Overflow: 1/4 in. Female Pipe Thread
Operating Pressure Range: 10-100 psig

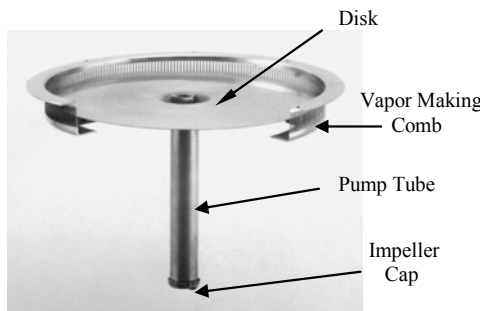
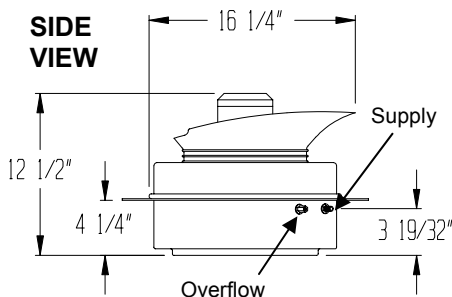
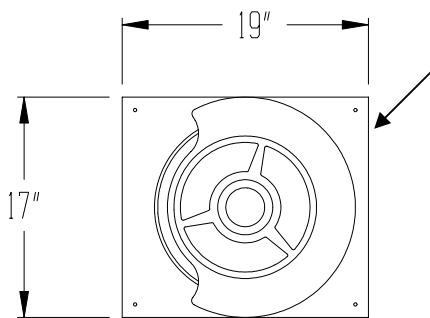

CENTRIFUGAL ATOMIZER

The heart of Humidity Source humidifier units is the patented masterfully engineered Centrifugal Atomizer. Water is drawn by centrifugal force up through the rotating impeller cap and pump tube, then spun across the disk rotating at 3250 RPM striking the Vapor-Maker Comb creating an extremely fine vapor. An integral fan under the rotating disk blows the vapor out of the unit resulting in a fine atomized vapor that is quickly absorbed into the air.

These specifications are subject to change without notice.

DUCT HUMIDIFIER APPLICATION DATA

Humidity Source positive capacity atomizing humidifiers produce moisture that will quickly evaporate in the surrounding air **if there is no impingement**. Strict attention to minimum clearance dimensions must be adhered to in order to avoid condensation.

ABSORPTION DISTANCE

Duct Air Velocity ft/min.	800	1000	1200
Absorption Distance Required	8'	10'	12'

Based on 65 F minimum and 30% R.H. maximum. Longer distances apply for lower temperatures or higher humidity.

Unit must be placed far enough downstream of an elbow or blower to prevent turbulence, normally 8' is sufficient.

SPECIAL REQUIREMENTS

Where minimum straight run distance are not available, one or more of the following procedures may apply:

1. Install a high limit duct humidistat at point of obstruction. Set at 95%. Barber Colman Co. Model HC-201.
2. Install moisture eliminator in duct at point of obstruction supplied by sheet metal fabricator. Pipe to drain.
3. Install reduced capacity impeller cap on bottom of pump tube. Available from Humidity Source.
4. Rotate rim slide (rim slide built into unit).
5. Seal all duct seams in 8' section downstream of unit and install duct drain.
6. Install perforated metal baffle upstream of humidifier to reduce turbulence and stratification of air flow.
7. If water supply is hard, install a demineralizer to prevent "white dust" from being formed.
8. Install temperature control to prevent operation below 65 F minimum temperature.

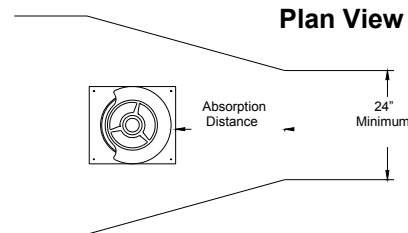
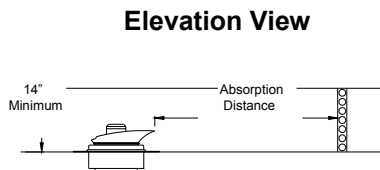
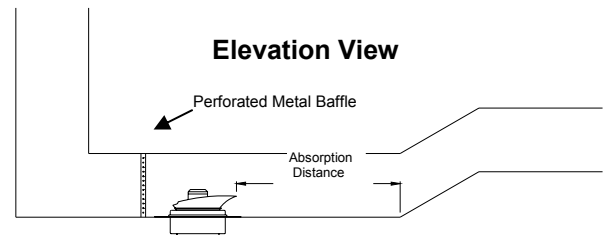
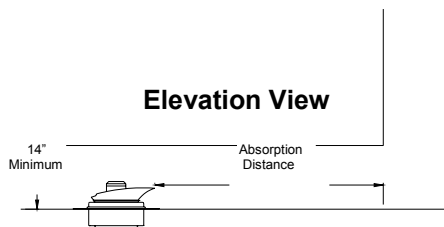
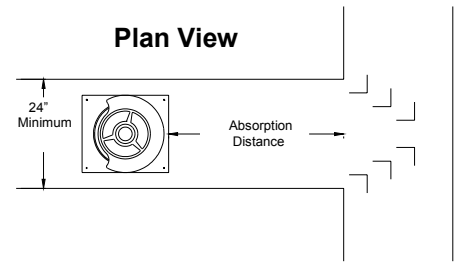
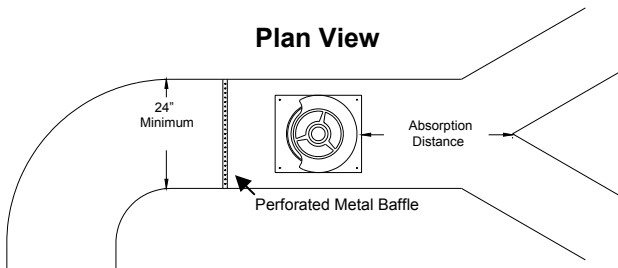

Humidity Source, LLC

90 Dayton Ave. Suite 58. Passaic, New Jersey 07055 USA
Ph. 973-916-1001 Fax 973-916-0770